



THE 5th INTERNATIONAL CONFERENCE ON

UNIVERSAL VILLAGE 2020

Evaluation of Transportation Systems and
Novel UV-Oriented Solution for

Integration, Resilience, Inclusiveness & Sustainability

Seek integrated systemic UV-oriented solutions for harmony, resilience, inclusion and sustainability.

CONTENTS

Part 1

Introduction

Part 3

Information Flow and Material Cycle

Part 5

Lifestyle and Community

Part 2

Current Transportation System and UV-Perspective

Part 4

Interaction and New Perspective

Part 6

Modeling and Proposed Framework

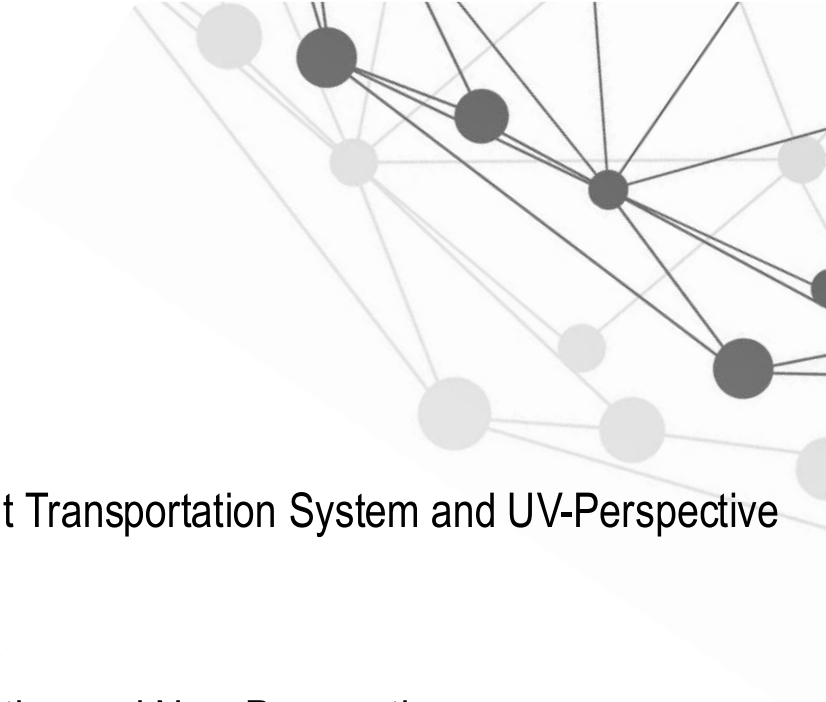

PART 01

Introduction

Importance of transportation, economics of transportation, safety and security issues, robustness & self-adaptability, intermodal transportation, first and secondary challenges, and limitations of development of transportation system



1.1 Definition of Transportation

Jingyuan Chen

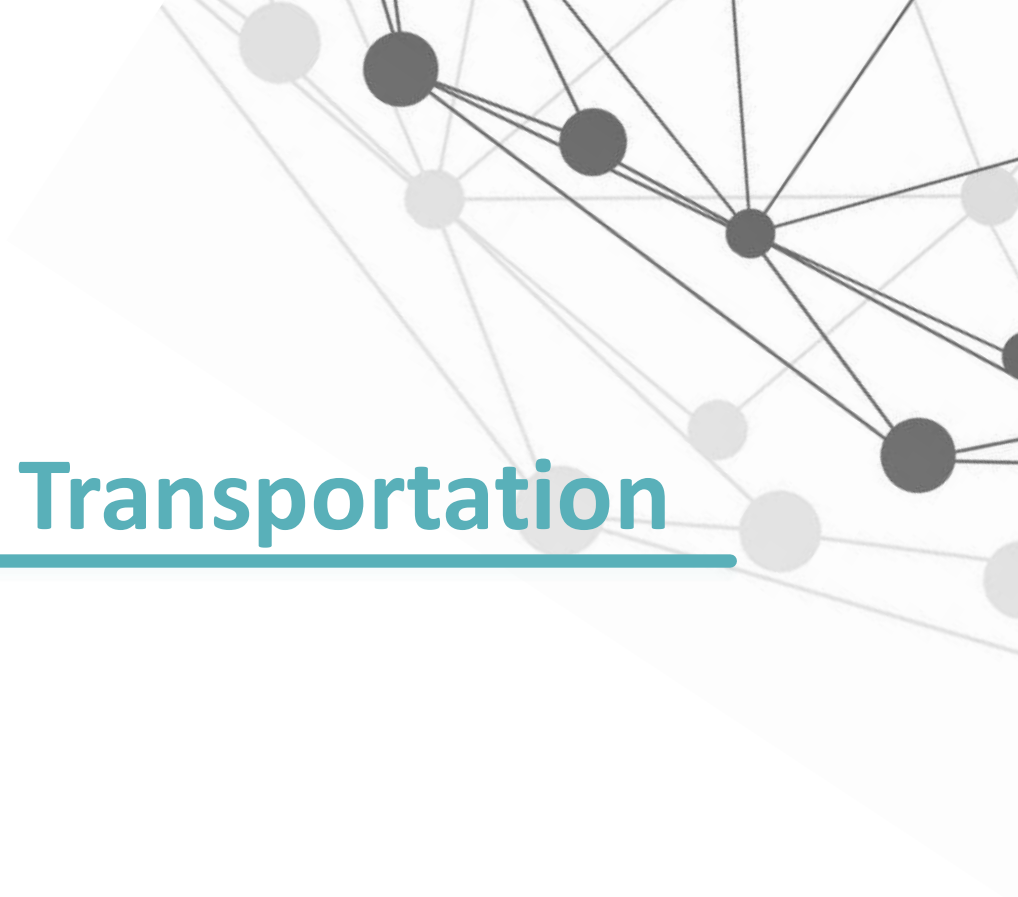

1.1.1 Transportation System

1. Definition:

Transportation systems can be defined as a combination of three basic elements:

- **transportation modes,**
- **transportation infrastructure,**
- transportation operations.**



1.1.1.1 Transportation Modes

Modes

- In order to meet different demands, the transportation system has many different modes that can be generally divided into
- four categories :
 - aviation,
 - waterborne
 - rail
 - road transport.

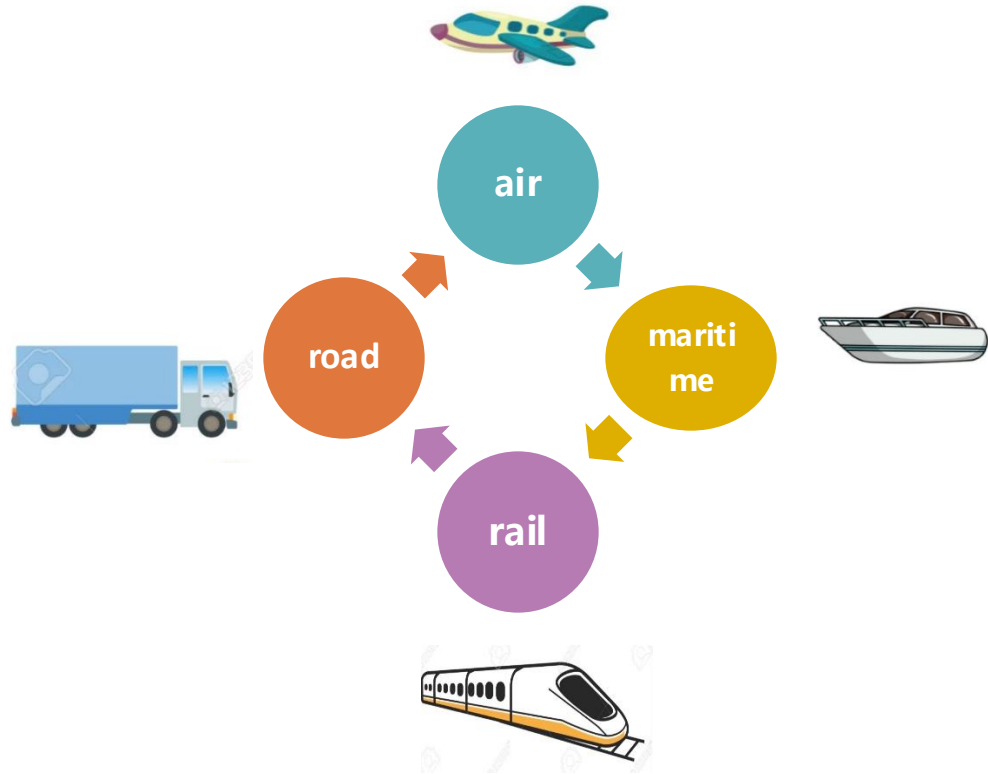

1.1.1.2 Transportation Infrastructure

1. Definition

Transport Infrastructure as one of the three crucial elements of transportation system refers to the combination of framework such as roads, canals, terminals, pipelines, airports, railway stations.





1.1.1.3 Different Targeted Transportation

1. Definition

The transportation demand has two different sources, which are **passenger** and **logistics** demands. Since these two types of transportation have different transportation requirements, they must be considered separately.

In the later paper, these two different orientated transportation will be discussed insolatedly.

1.2 Economics of Transportation

Lixin Xu & Yunpeng Fang



1.2.1 Macroscopic Economic Scale

Region

- The US spent \$ 1,852.9 billion on transportation in 2018, accounting for 9% of GDP [1]
- In EU, the transportation industry employs 10 million people and takes up 5% of GDP

Modes

- In terms of freight flow, truck took the most part (62.28%) in North America in 2017. [3]

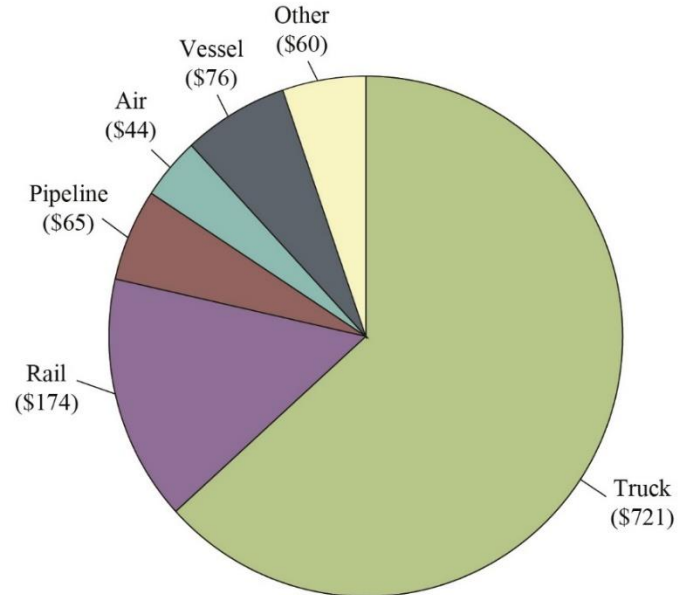

[1] U.S. Gross Domestic Product (GDP) Attributed to Transportation Functions | Bureau of Transportation Statistics

[2] <https://ec.europa.eu/jrc/en/research-topic/transport-sector-economic-analysis>

[3] <https://www.bts.gov/newsroom/2017-north-american-freight-numbers>

1.2.1 Macroscopic Economic Scale

Transportation Infrastructure - Economies of African Railroad

A bunch of transportation projects are in progress, such as:

- Tanzania–Gabon railway (\$33 billion),
- Mombasa–Kampala–Kigali railway (\$14 billion),
- Trans- Kalahari railway (\$9 billion),
- Abidjan–Lagos motorway (\$8 billion)

These projects have infused great economic vitality into the African economies.

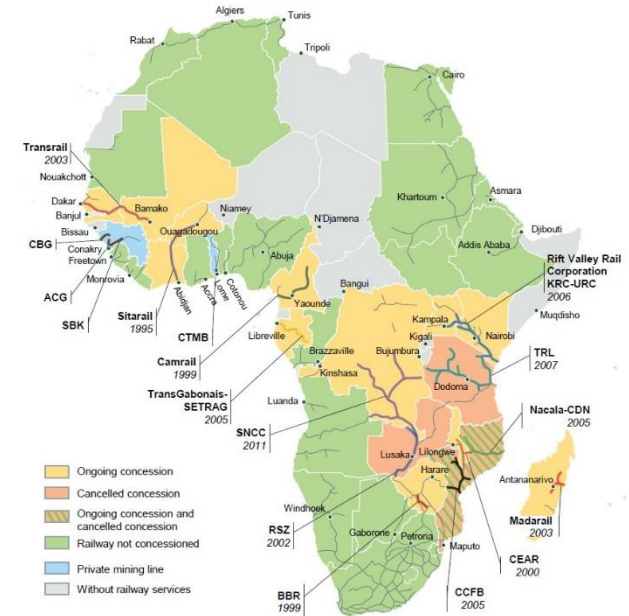

Source : ALG based on AfDB data

(*) Rail Infrastructure in Africa, Africa Development Bank

1.2.1 Macroscopic Economic Scale

Transportation Infrastructure - Economies of Beijing Daxing International Airport

- Having one of the largest single-structure airport terminals in the world
- Covering an area of more than 700,000 squared meters (7,500,000 squared feet)
- Long term target of 72 million passengers, 2 million tons of cargo and mail, and 620,000 aircraft movements
- To bring 8.6 trillion RMB profit to Beijing in the next 20 years



https://en.wikipedia.org/wiki/Beijing_Daxing_International_Airport



1.2.1 Macroscopic Economic Scale

Challenges and Costs

Traffic Congestion

- Traffic congestion cost \$87 billion in the US (2018)
- Congestion costs nearly EUR 100 billion annually, or 1 % of the EU's GDP
- In China, Beijing's annual bill for congestion amounts to 70 billion yuan (\$11.3 billion)

Waste from transportation incidents

- The price tag for car accidents on America' s roads and highways is \$ 871 billion in 2010, which is nearly \$900 for every person living in the U.S. that year.

1.2.1 Macroscopic Economic Scale

Challenges and Costs

Fuel Consumption

- In 2019, about 142.17 billion gallons of gasoline were consumed in the U.S., that is an average of about 389.51 million gallons per day.

Vehicle Emissions

- In 2014, about a quarter of the EU' s total GHG (greenhouse gas) emissions came from transport.

Overall GHG from Transport in EU28

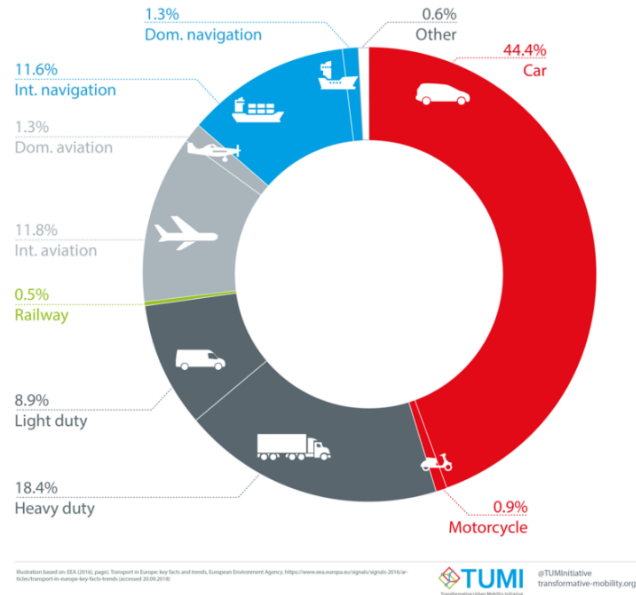

https://en.wikipedia.org/wiki/Environmental_impact_of_transport



Chart — Contribution of the transport sector to total emissions of the main air pollutants

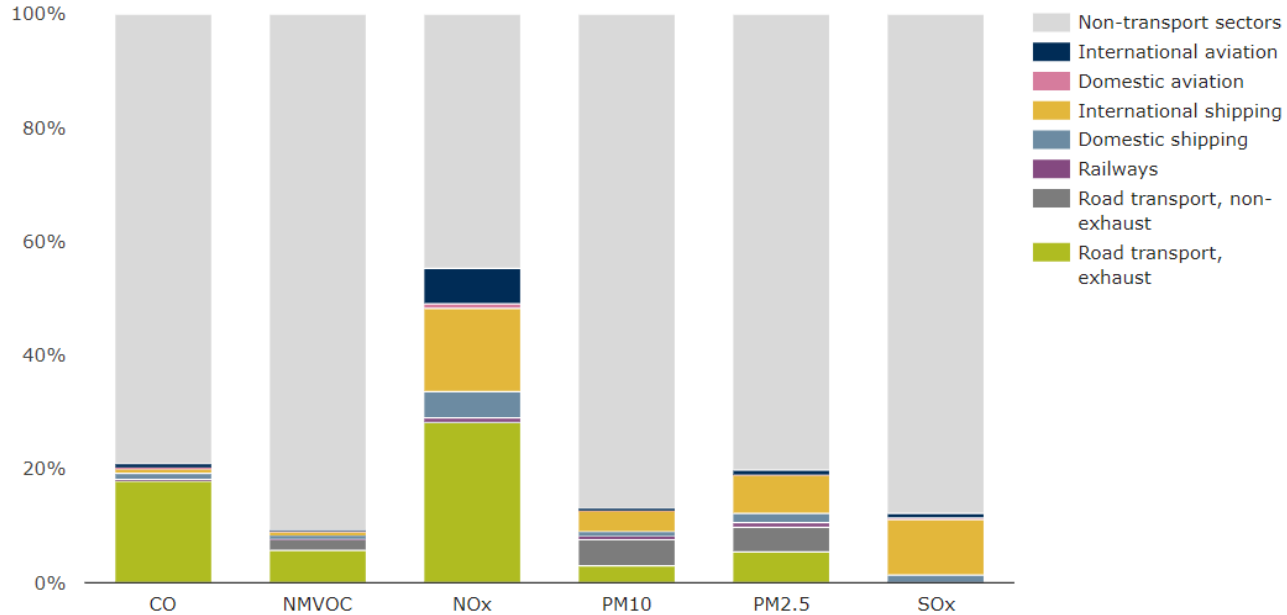

According to European Environment Agency, in transport sectors, the most exhaustion of CO and NOx is created by road transport.

<https://www.eea.europa.eu/data-and-maps/indicators/transport-emissions-of-air-pollutants-8/transport-emissions-of-air-pollutants-8>

1.2.1 Macroscopic Economic Scale

New economic modal

The global sharing economy are forecasted to reach \$355 billion by 2025 in terms of travel, car sharing, finance, staffing and streaming.

Bike Sharing

- Mobike is one of the biggest bike-sharing company in China. As of 2018, Mobike had operated in over 200 cities and 19 countries around the world.

Chart 5: Selected Smart Commute Companies

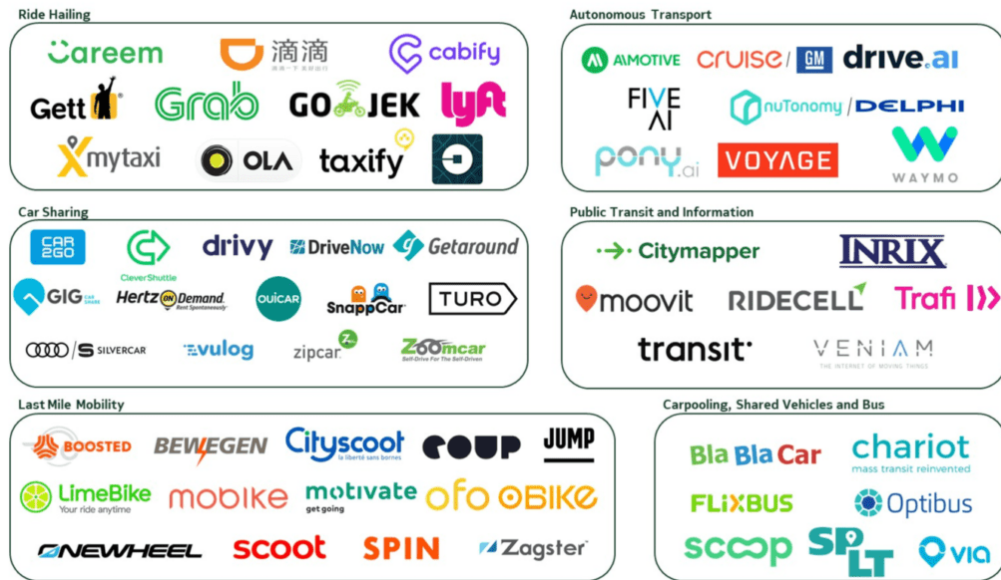

<https://www.cbinsights.com/research/transportation-service-smart-commuting/>



Summary

In this part, we discussed the economics of transportation on a **macroscopic** level, including:

- The proportion that transportation takes in GDP
- The percentage of each transportation modes (North America)
- Transportation infrastructure like African railway and Beijing Daxing Airport
- The challenges and costs on an economic level
- Emerging new economic modals

In the next part, we will discuss the economics of transportation on a **microscopic** level.



1.2.2 Microscopic Economic scale

Defination

- At the microeconomic level (**the importance of transport to specific parts of the economy**), it involves the interrelationship between Transportation, producers, consumers and distribution costs.
- Therefore, the microeconomic can use to assess the importance of specific transport activities and infrastructure in various sectors of the economy.
- This part will demonstrate the correlation between economy and traffic from the perspective of microeconomics in three aspects: **policy, travel mode and travel cost.**



1.2.2 Microscopic Economic scale

The impact of policy on Transportation

the case in portions of the South Bay Cities north of the Port of Los Angeles.

As the table 1 shows, government taxes could **rise significantly** by rezoning the land used for shipping. However, the occupation of industrial land can generate a lot of transportation costs. Take trucks as an example: an average increase of **25 miles** per vehicle at the port for one-way transportation. It is estimated that an additional transportation cost of **\$43** per vehicle

Land Use	Annual Local Tax Revenues to City General Funds	Tax Revenues Per Sq. Ft. of Land
Warehouse	\$61,000	\$0.28
Light Industrial/Manufacturing	\$57,200	\$0.26
R&D Flex	\$80,600	\$0.37
Retail	\$306,300	\$1.41
Business Park/Campus	\$189,700	\$0.87
Office – 3-story	\$286,600	\$1.32
Office – 8-story	\$687,400	\$3.16
Townhouses	\$99,300	\$0.46
Apt./Condos/Lofts – 45/acre	\$169,600	\$0.78
Apt./Condos/Lofts – 100/acre	\$384,200	\$1.76

Table 1: Tax revenue estimates for hypothetical development, inner east bay of San Francisco bay area.

ICF International (Firm). Impacts of Public Policy on the Freight Transportation System[M]. Transportation Research Board, 2011.

1.2.2 Microscopic Economic scale

The impact of policy on Transportation the case in Port of Baltimore

The Port of Baltimore is a major East Coast port handling more than **41 million short tons** in 2007.

Because of the importance of Baltimore Port, the government has **continued the zoning policy (shown in the figure1)** until **2024** to protect freight costs.

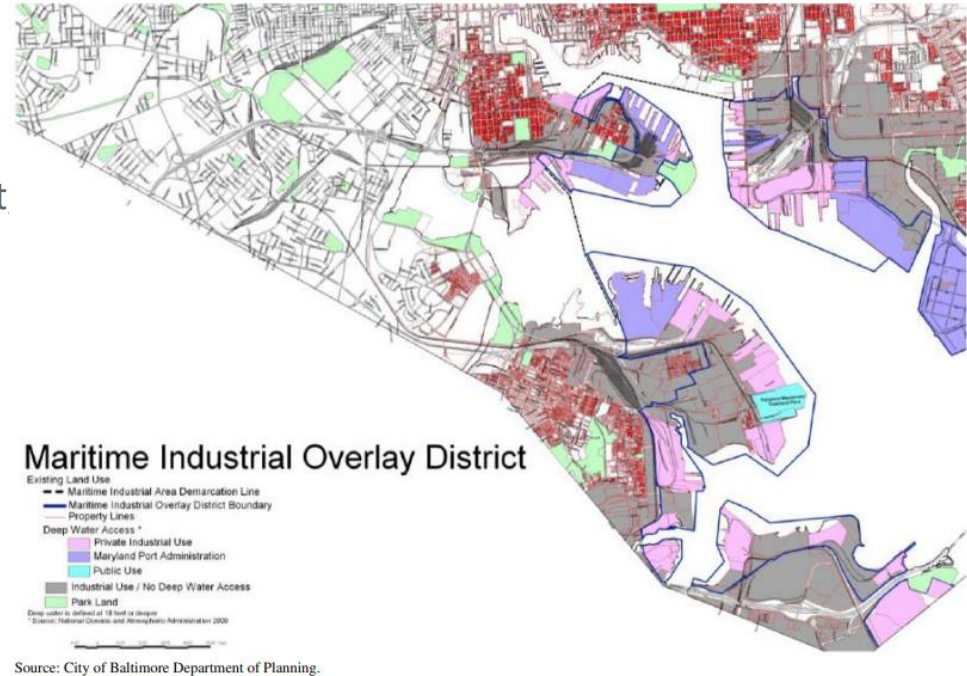

Figure 1. Baltimore maritime industrial overlay district



1.2.2 Microscopic Economic scale

The influence of microeconomics on different modes of Transportation

Demand for passenger transportation

From the perspective of **fuel economy**, the choice of passenger transport mode is studied :

- **Railways** have a relatively **high fuel economy** value because of their higher passenger volume and high electrification rate.
- **Airlines** have become a **more economical** and efficient way to travel, because of the popularity of air travel and the help of various booking software.
- **Motorcycles** are **economically** efficient per gallon of fuel because of their portability and their relatively high fuel efficiency.
- The economic efficiency of **public Transportation** is **low** because of the low load rate.
- **Demand response vehicles** are **the least efficient** because they need to burn unnecessary fuel to get passengers.

Average Per-Passenger Fuel Economy by Travel Mode

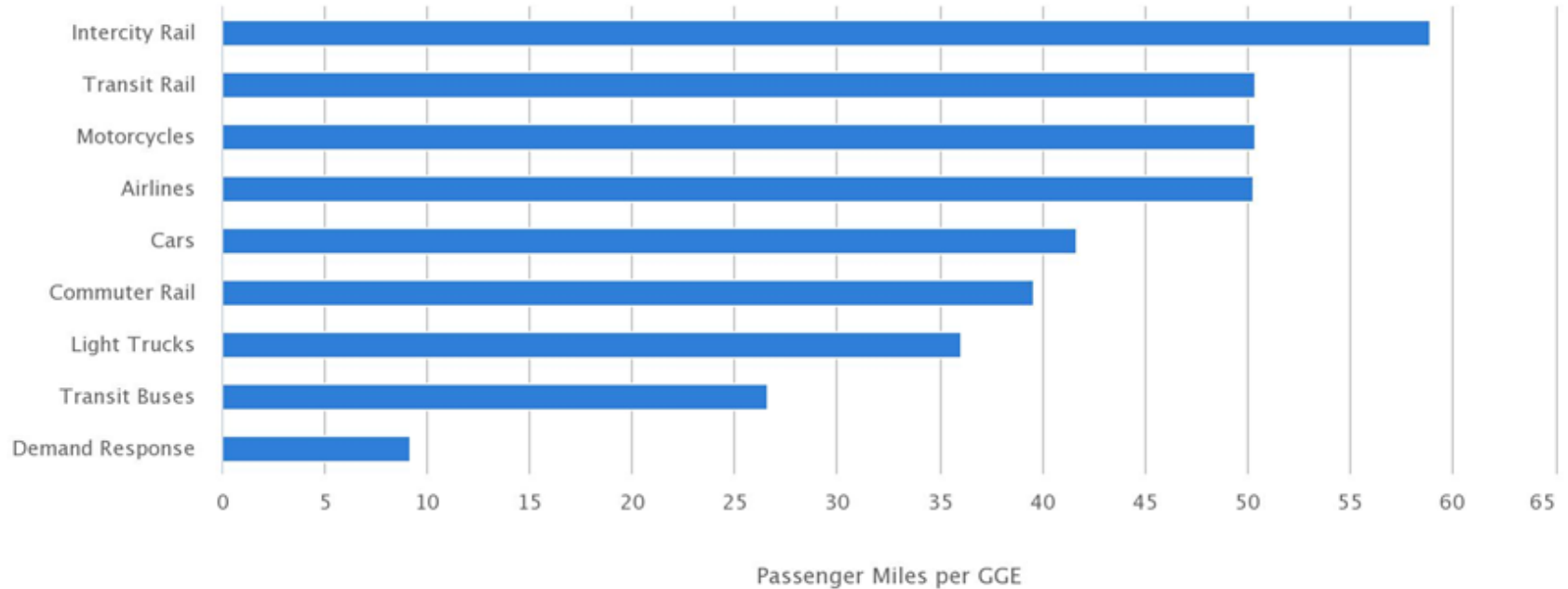

Last updated: May 2020

Printed on: August 16

From the perspective of fuel economy, the choice of passenger transport mode

Oak Ridge National Laboratory, Transportation Energy Data Book 38. 2020, Table 2.13. British thermal unit (BTU) to GGE conversion taken from Appendix A3 of the U.S. Energy Information Administration (EIA) Monthly Energy Review, February 2020.

1.2.2 Microscopic Economic scale

The influence of microeconomics on different modes of Transportation

Demand for freight transportation

This image, provided by the U.S. Department of Transportation, showed seasonally adjusted freight data.

1. the reduction of coal transportation, the number of goods transported by railway decreases
2. the global economic weakness from around 2011 to the end of 2013 led to a stagnation in air freight traffic.

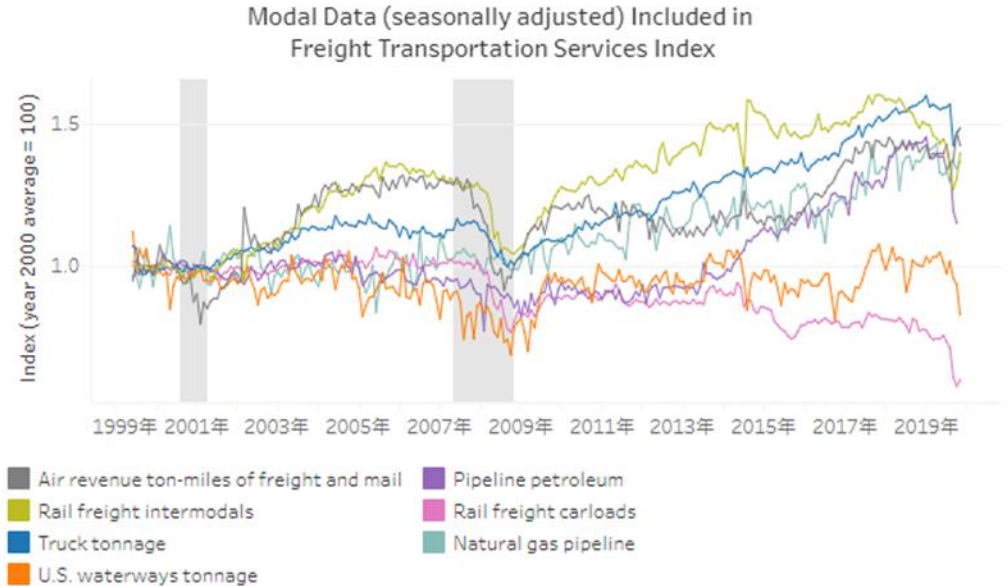

U.S. Department of Transportation, Bureau of Transportation Statistics, seasonally adjusted transportation data. Available at <https://www.transstats.bts.gov/OSEA/SeasonalAdjustment/>

1.2.2 Microscopic Economic scale





Factors that affect the cost of travel

the impact of traffic congestion on economic costs.

Table 1 shows the top ten traffic jams in the United States in 2019.

For the second consecutive year, **Boston traffic as the most lasting** city in the U.S. with the average traffic in the metro area **losing 149 hours per year** to traffic, **costing \$2,205 per driver** in time lost.

Table 1: 10 Most Congested Urban Areas in the U.S.

2019 CONGESTION RANK (2018)	URBAN AREA	HOURS LOST IN CONGESTION	2018-2019 CHANGE	2017-2018 CHANGE	INCIDENT IMPACT	COST PER DRIVER	TOTAL COST PER CITY	BIKE	TRANSIT	LAST MILE SPEED (MPH)
1 (1)	Boston, MA	149	-5%	3%		\$2,205	\$4.1B			12
2 (3)	Chicago, IL	145	4%	0%		\$2,146	\$7.6B			11
3 (5)	Philadelphia, PA	142	4%	5%		\$2,102	\$4.5B			10
4 (2)	New York City, NY	140	-4%	-3%		\$2,072	\$11B			11
5 (3)	Washington DC	124	-11%	4%		\$1,835	\$4.1B			10
6 (7)	Los Angeles, CA	103	4%	-8%		\$1,524	\$8.2B			16
7 (6)	San Francisco, CA	97	-8%	-4%		\$1,436	\$3B			10
8 (9)	Portland, OR	89	10%	-7%		\$1,317	\$1.2B			14
9 (11)	Baltimore, MD	84	5%	9%		\$1,243	\$1.3B			10
10 (12)	Atlanta, GA	82	9%	-3%		\$1,214	\$3.0B			12

Traffic Scorecard". INRIX. Retrieved October 23, 2014.



1.2.2 Microscopic Economic scale

Factors that affect the cost of travel

The economic impact of automated Transportation

1. Driver's wages account for most of the city's public transportation costs.

- In Singapore and Australia, the driver's fee accounts for 40% to 70% of the total bus driver's cost
- In Japan, driver's pay accounts for 53 percent of bus and 70 percent of taxi operating costs, respectively
- About 1/3 of the total cost of the bus operator in Santiago

2. Automation has a significant impact on reducing the cost of Shared mobile travel

- In Zurich, automation could minimize taxi travel costs by 85%
- in Singapore, the total operator costs of an electric 6-m long shuttle bus are reduced by 70% if automated, as compared to its human-driven equivalent.
- Wadud made a more conservative estimate for the United Kingdom, estimating cost savings of 30% for the taxi industry and 15%-23% for the truck industry, after assuming that automation would still require 40% of existing driver costs.

Tirachini A, Antoniou C. The economics of automated public transport: Effects on operator cost, travel time, fare and subsidy[J]. Economics of Transportation, 2020, 21: 100151.



Summary

In this part, we discussed:

- The definition of micro-economics of transportation
- The **impact of policy** on Transportation and gave two cases
- The influence of microeconomics on **different modes** of Transportation
- The **factors** that affect the cost of travel

In the next part, we will be focusing on the **safety and security** of transportation system.

1.3 Safety and Security of Transportation System

Yiyao Wang





1.3.1 Safety of the Transportation system

Annual human loss in the whole world due to road traffic crashes:

1.15 million people in 2000

1.35 million people in 2016 [CDC]

Road traffic injuries are estimated to be the eighth leading cause of death globally for all age groups and the leading cause of death for people 5–29 years of age. [CDC]

Leading factors for fatalities of transportation system:

- Construction
- Transport
- Traffic

1.3.1 Safety of the Transportation system

Construction factors - construction process

In United States

- Nearly 40% of workplace fatalities are caused by transportation-related incidents in 2018 [CFOI].
- About 70% of total highway, street, and bridge construction accidents are caused by transportation incident in 2020 [ARTBA].



Courtesy RoadsBridge

1.3.1 Safety of the Transportation system

Construction factors - construction process

In 2009, a medieval building collapsed and two residents in it lost their lives during the excavation of a underground tram line beneath it in Cologne, Germany.

In 2013, 5 workers were buried in a cave-in accident during the construction of Xi'an's underground tram in China.



Courtesy Der Spiegel



1.3.1 Safety of the Transportation system

Construction factors - finished construction facilities

The annual investment required to maintain roads, highways, and bridges in the U.S. is roughly \$185 billion a year.

Structurally deficient bridges

- More than 46,000 structurally deficient bridges in U.S, requiring more than 50 years to repair.
- Queen Isabella Causeway's collapse caused 8 deaths and shut down of electricity and fresh water to South Padre Island.
- The 2007 I-35W Mississippi River bridge collapse leads to 13 deaths and 145 injuries.

1.3.1 Safety of the Transportation system

Construction factors - finished construction facilities

Dangerous roads

- Pothole damage costs American motorists \$3 billion per year.
- Almost 3,000 people died due to pothole road accidents each year in India.
- An average of 1,836 deaths and 136,309 injuries every year are related to snowy and icy roads in U.S., 3.6 times the total death from all other weather hazard.



Black ice, Courtesy Weloveweather

1.3.1 Safety of the Transportation system

Transport factors - hazardous freights

- Over one billion tons of hazardous materials are transported by road, involving 11,600 enterprises, more than 360,000 vehicles, 32million people in China every year.
- In 2017, over 2.9 billion tons of hazardous materials are transported in US, worth more than 1680 billion dollars.

HazMat shipment value by mode for USA, 2017 (in billion dollars)

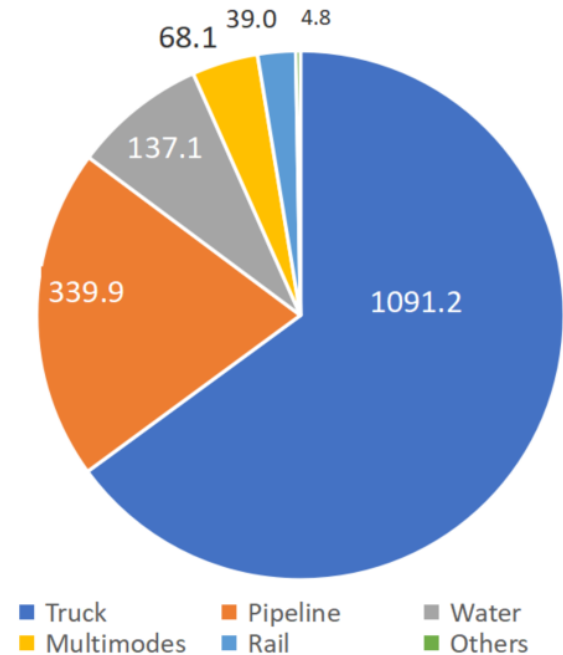



1.3.1 Safety of the Transportation system

Transport factors - hazardous freights

In 2019 U.S.

- Over 22,745 hazardous materials accidents happened by all modes
- Top 3 hazard class are flammable (9692), corrosive (6936) and oxidizer (1304) materials.
- Caused 91 million dollars along with 6 fatalities and 179 injuries.

1.3.1 Safety of the Transportation system

Traffic factors - Fatigue driving

- About 32% drivers drive while fatigued at least once a month in U.S.
- 1 in 25 adult drivers report having fallen asleep while driving in the previous 30 days. [CDC]
- 20% traffic accidents involve fatigue driving worldwide.
- In 2017, a conservative estimation of 91,000 police-reported crashes involved drowsy drivers, leading to approximately 50,000 people injured and nearly 800 deaths in United States. [NHTSA]





1.3.1 Safety of the Transportation system

Traffic factors - Road rage

- 33% of total traffic accidents are related to road rage. [NHTSA]
- In U.S., road rage-related fatalities have increased by over 500% in the last decade. [PolicyAdvice]
- Gun-related cases doubled between 2014 and 2016. [PolicyAdvice]
- In China, more than half conflict cases on bus involve passengers' aggressive behavior to drivers, and passengers rob bus control devices in over 30% cases. [ChinaCourt]



1.3.1 Safety of the Transportation system

Traffic factors - Suicide

- Motor vehicle collision is a typical method for people to commit suicide.
- Railway suicides proportion increased from 3.5% to 4.9% in England from 2000 to 2013.
- 277 of 318 people successfully commit railway suicide in 2017 in U.S., and so did 281 out of 318 in 2018. [Federal Railway Administration]

1.3.1 Safety of the Transportation system

Traffic factors - Elders

- Licensed driver aged 65 and older in United States increase 63% between 1999 to 2017.
- Senior drivers have 17 times higher fatality rate than other drivers, due to their weaker muscles and reduced flexibility to complete some actions.
- 65+ ages seniors take up 20 percent of all pedestrian fatalities.



Courtesy HelpGuide

1.3.2 Security of the Transportation System

The Global Economic Impact Of Terrorism

Economic impact of terrorism from 2000 to 2018 (billion U.S. dollars)

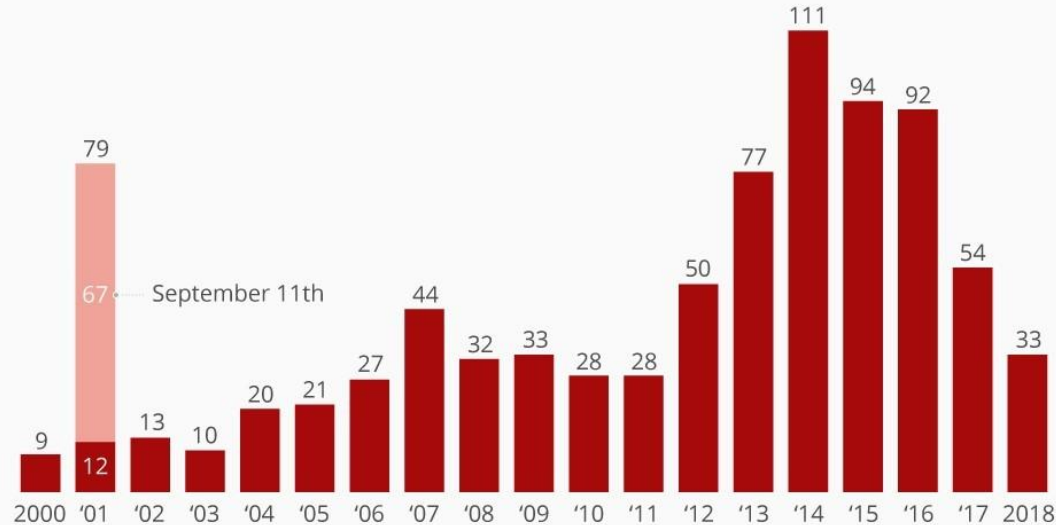

@StatistaCharts

Source: 2019 Global Terrorism Index

statista



1.3.2 Security of the Transportation System

Physical terrorism attacks

- Wall Street bombing killed 40 people and injured hundreds of people (1920).
- 911 attacks resulted in 2977 deaths and over 25,000 injuries (2001) .
- Terrorist attack at Kunming railway Station lead to 31 deaths and more than 140 injuries (2014).



1.3.2 Security of the Transportation System

Cyber attacks

- In 2008, a 14-year-old Polish teenager modified a TV remote control to manipulate the Lodz tram network, derailing four tram cars and injuring 12 passengers
- A cyberattack shut down passport control system at Istanbul Ataturk International Airport in 2013. Passengers were delayed for many hours until the authority restored the system after recovery operation, but the attacker has still not been found.
- VANET will face great security challenges in the future.



Summary

In this part, we discussed:

- The **safety** of transportation system in terms of **construction, transport** and **traffic** factors, and gave examples such as hazardous freights, fatigue driving, road rage and suicides.
- The **security** of transportation system, and gave examples such as **terrorists attack** and **cyber attacks**.

In the next part, we will be focusing on the **robustness and self-adaptability** of transportation system.

1.4 Robustness & Self-adaptivity

Lin Li



1.4.1 Introduction

With the popularity of ITS technology, travel is becoming more and more convenient and comfortable. However, traffic system has therefore become more and more complicated and interdependent, which let the system more vulnerable to accidents or disasters. It is significant to handle the abnormal events or disturbances that occur in the system to maintain system robustness and stability.



1.4.2 Categories of Different Disturbances

Disturbances can be classified as minor disturbance, accident and calamity based on the damage to the system:

- **Minor disturbance** is an abnormal event likely to affect the normal operation of the system but can be resolved without or with minor intervene. Typical minor disturbances are slight traffic jam, pedestrians crossing the road or power failure of a single traffic light, etc.



1.4.2 Categories of Different Disturbances

- **Accident** means abnormal event which are very likely to affect the normal operation and probably cause casualties and property damage, and the system may not be easy to handle it. Typical accidents are car accident, bad weather, blackout in the city or mass parade without supervision, etc.



1.4.2 Categories of Different Disturbances

- **Calamity** is very severe crisis, natural disaster or large scale of general accidents which do great damage to the system and human. Typical calamities are serious multi-vehicle rear-end collision, storm, tsunami and hurricane, traffic jams of millions of cars or terrorist attacks, etc.



Different levels of disturbance will cause different damages to the system, and it is important for the systems to handle all kinds of the disturbances. Below we will analyze the damage of different disturbances.



1.4.3 Significant impact of minor disturbance

Current Transportation Systems pay little attention to minor disturbances because problems rarely get worse and it is too complicated to handle various disturbances. Though minor disturbances usually cause little damage to the system, the high frequency of them will still reduce people's living qualities.

Here we will talk about common minor disturbances like:

- Pedestrians' Illegal Crossing,
- Illegal Parking,
- minor collisions,
- traffic congestion.

Pedestrians' Illegal Crossing,

Pedestrians' illegal crossing is a typical minor disturbance. Though this kind of minor disturbance may cause little damage to human, the overall impact is significantly high when the number is too high.

- 35% of pedestrians entered illegally at a signalized crossing [y1].
- The traffic capacity drops by about 10%–30% and the delay to vehicles increases by between 100% and 400% for different pedestrian arrival frequency [z1].
- if a car stops 2.4 more times per kilometer, that would increase fuel consumption by 50%[q1].
- In 2014, there were 2242 pedestrian accidents in China, with 1247 deaths, averaging 3.42 deaths per day.

The traffic flow will be frequently interrupted by illegal crossing, and it probably leads to serious traffic jam. The overall damage to human safety will be serious for the universality of the phenomenon.



Illegal Parking

Car's illegal parking is another annoying minor disturbance. Inappropriate parking place will slow the traffic flow. The **traffic capacity will reduce by approximately 7% per 100 roadside parking** [z2]. In some special places, illegal parking may also cause some accidents, especially in some places like schools or train stations. When the percentage of students transported **by private car increases from 20% to 40%, the road capacity decreases from 0.706 to 0.596** [z3]. Traffic at the school gate will become congested and chaotic during school hours, thus students are more vulnerable to get hurt by pick-up cars.



Minor Collisions

Minor collisions between vehicles rarely cause injuries, but it may cause severe traffic jam if no handled well. If the collision vehicles stay in place after the collision, **it may block a traffic lane and cause traffic jam**. For instance, A minor collision between a big rig and a silver SUV in Merced, together with 2 other minor accidents happened nearby, led to an 8.5-mile traffic jam [z4].

The minor collisions may also lead to **serial rear-end collision** and cause huge injuries and damage. For example, a commuter bus collided with a tractor, which subsequently caused the bus to careen and roll, resulting in a further collision with an oncoming articulated lorry, and at least 22 people, including four children were killed in this accident [z5].



Traffic Congestion

Traffic congestion is also a slight minor disturbance and rarely cause big damage. But traffic jam is so common and annoying which make it a significant problem. The average American driver lost 99 hours a year in traffic in 2019. Nationally, drivers lost more than **\$88 billion** in time to congestion.



1.4.4 Severe impact of accidents and calamities

Accidents and calamities will probably cause a large number of casualties and property damage.

- An average of 1.3 million people die in road crashes every year.
- Motor vehicle crashes cost the United States alone almost \$1 trillion per year[2].
- The economic damage caused by Hurricane Sandy to the New York City transportation system reached up to 7.5 billion US dollars[1].
- Sichuan earthquake partially disrupted 21 highways and 5 more that were under construction. Five national roads and 11 provincial roads were severely destroyed[1]



1.4.4 Severe impact of accidents and calamities

Additionally, it may probably cause some severe secondary effects like environmental pollution and long-term socioeconomic impacts. Major oil spills from wrecked vehicles are one of the biggest problems with transportation accidents, particularly those that happen near water. Many car parts are also left on the side of the road where they can harm animals or plants[2].

From the perspective of long-term socioeconomic and psychological impacts, huge crisis may also affect traveler decisions. Gordon et al. (2007) identified a 6% reduction in passenger trips and a large shift from public transit services to private automobiles during a two-year period following the 9/11 attacks[3].



1.4.5 Butterfly effect of minor disturbances

Minor disturbances may have butterfly effect which means they may lead to severe accidents or calamity. The neglect of minor disturbance and improper handling of the problem may probably make the butterfly effect happen.

For instance, Road problems like pot holes on road is a typical minor disturbance and cause little damage to the system, but when the government starts the maintenance in rush hours, it probably leads to a calamity. In August 14, 2010, huge cargo trucks heading to Beijing, along with National Highway 110's maintenance work causes the insane traffic jam slowing thousands of vehicles for more than 100 kilometers (60 mi) and lasted for nine days [x2].



1.4.5 Butterfly effect of minor disturbances

In order to avoid the butterfly effect of minor disturbances, **nipping the disturbances in the bud** are much better than handle them when they are becoming serious and dangerous. It is significant for current researchers to pay more attention on handling minor disturbances.





Summary

We have talked about The impact of different kinds of disturbances:

- The impact of minor disturbances that are often overlooked
- The severe impact of accidents and calamities
- The butterfly impact of minor disturbances'

It shows that we need to develop **a hierarchic and systematic** method to handle all of them together. Only in that way we can satisfy the high requirement and challenges of Robustness & Self-adaptivity.

1.5 Intermodal Transportation

Lixin Xu



1.5 Intermodal Transportation

Paris-CDG Airport

- Located in Roissy-en-France
- 2nd in Europe, 10th around the world [1]
- 76,150,007 passengers and 498,175 aircraft (2019)

Travel to Center of Paris

- line B of the RER network – 35 min
- CDG Express - 20 min (till 2024)

Travel to Major French Cities [3]

- Terminal 2 TGV



Paris-CDG Airport [2]

[1] https://en.wikipedia.org/wiki/Charles_de_Gaulle_Airport

[2] <https://www.aircosmosinternational.com/article/green-light-for-paris-cdg-airport-express-train-link-1782>

[3] <https://easycdg.com/tgv-train-paris-cdg-airport-charlesdegaulle/>



1.5 Intermodal Transportation

Frankfurt Airport

- Located at 16km south-west to the center of Frankfurt, at the intersection of Highway A3 and A5
- 12 min's ride to Frankfurt (Main) Hauptbahnhof

Air-Rail Intermodality [1]

As early as 1995, Frankfurt has completed the infrastructure of air-rail integration, including Regional Trains, Long Distance Trains, and the air-rail building.

Influence to the Air-Rail Hub Area [2]

- Economic vitality and prosperity
- International Convention and Exhibition Metropolis
- Rise of employment rate

[1] QIN Cancan, XU Xunchu. On Air-Rail Intermodality in Frankfurt Airport.

[2] Hou Mingming. Research on the Construction of HST Transportation Hub and Urban Development



Summary

In this part, we presented two examples of **intermodal transportation**, which is crucial to our modern transportation system and provides passenger a **more integrated traveling experience**.

In the next part, we will be focusing on the **challenges caused by transportation system**.

1.6 Challenges caused by transportation system

Yuanning Chang





1.6.1 Environmental challenges

- **Air pollution**
- **Water pollution**
- **Land use and pollution**
- **Noise pollution**
- **Biodiversity**

1.6.1 Environmental challenges

Air pollution

- One of the main environmental impacts caused by transportation systems
- Transportation shares 24% of total direct CO2 emission from fuel combustion[1]
- CO2 emission growth is slowing down in recent years

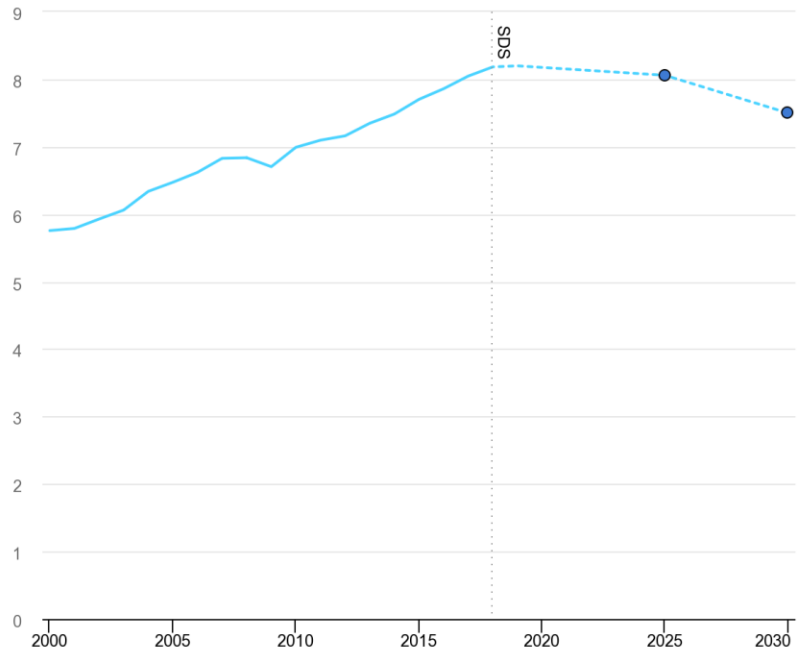

IEA, Transport sector direct CO2 emissions in the Sustainable Development Scenario, 2000-2030, IEA, Paris
<https://www.iea.org/data-and-statistics/charts/transport-sector-direct-co2-emissions-in-the-sustainable-development-scenario-2000-2030>



1.6.1 Environmental challenges

Air pollution

Road vehicles

- 75% of CO₂ emission from transportation system are from road vehicles[1]
- Electrical vehicles can help reduce CO₂, but battery production also emit greenhouse gases
- All kinds of vehicles produce particulate emission, which would form smog

Planes and ships

- Emission of NO_x from large jet plane help forming ozone in upper troposphere
- Exhaust gases from ships contain large amount of sulfur
- Both planes and ships produce CO₂, CO, and particulate
- CO₂ and NO_x in atmosphere can create acid rain

[1] <https://www.iea.org/reports/tracking-transport-2020>



1.6.1 Environmental challenges

Water pollution

Marine transportation

- Marine transportation accounts for the most important source of water pollution in the transportation system
- Oil spills
 - PAH in crude oil is toxic to marine wild life
 - Oil is difficult to be cleaned up in sea and PAH can stay in sediments for years
- Waste water
 - On average, each cruise ship dumps 255,000 US gallons (970 m³) of greywater and 30,000 US gallons (110 m³) of blackwater into the sea every day[1]
 - They contain harmful nutrients, bacteria, virus, ...
- Ballast waters
 - Ballast waters discharge may bring invasive species to new place



1.6.1 Environmental challenges

Water pollution

Other transportation systems

- Aviation: Airlines use ethylene glycol or propylene glycol for aircraft deicing, polluting water near the airport
- Road transport: Sodium acetate, glycol compounds and other chemical compound are also used for road deicing, which may pollute water near the road.

[1] Walker TR, Adebambo O, Del Aguila Feijoo MC, Elhaimer E, Hossain T, Edwards SJ, Morrison CE, Romo J, Sharma N, Taylor S, Zomorodi S (2019). "Environmental Effects of Marine Transportation". World Seas: An Environmental Evaluation. pp. 505–530.



1.6.1 Environmental challenges

Land use and pollution

- Transportation infrastructure uses a large amount of land
- Roads and parking lots account for 35% to 50% of the land use footprint in some cities[1]
- Toxic material caused by fuel spill and other road maintenance is found near roads, railroads and airports

[1] https://transportgeography.org/?page_id=5711



1.6.1 Environmental challenges

Noise pollution

- Roadway noise from motorcycles
- Aircraft noise from aircraft engines and airflow around aircrafts
- Noise from engines and sonars on ships
 - Noise from ships transformed the acoustic habit of marine animals
 - They rely on sound for navigation or communication



1.6.1 Environmental challenges

Biodiversity

- Land use lead to deforestation
- Draining wetlands threaten the water plant species
- Long-distance transportation systems may bring invasive species to another place



1.6.2 Healthcare

- **Air pollution**
- **Impact of climate change**
- **Light pollution**
- **Noise pollution**



1.6.2 Healthcare

Air pollution

- One of the cause of cancer, cardiovascular, respiratory, and neurological diseases
- CO: reduces the oxygen supply in the circulatory system
- NO₂: reduces lung function, affect the respiratory immune defense system
- Particulates in smog: respiratory problems, skin irritations, eyes inflammations

Percent in diseases that is linked to worldwide ambient air pollution according to WHO:

Disease	Percent
Chronic obstructive pulmonary disease	43%
Lung cancer	29%
Ischemic heart disease	25%
Stroke	24%
Acute lower respiratory infection	17%

[1] <https://www.who.int/airpollution/ambient/health-impacts/en/>



1.6.2 Healthcare

Impact of climate change

- Food and nutrition
 - Extreme weather can destroy crops, block food transportation
 - Increased drought encourages pests and the spread of the mold that produces aflatoxin
 - People may have liver diseases after eating contaminated food
- Heat
 - Global temperature rises
 - More heat events
 - Extreme heat events can cause heat exhausting, heat stroke and death



1.6.2 Healthcare

Impact of climate change

- Mental health
 - Long-term exposure to extreme weathers can bring stress to human
 - Extreme weathers bring damage to property, even cause injury or death, causing more mental health problems and stress-related diseases
 - Prolonged heat or cold events can create chronic stress to people



1.6.2 Healthcare

Light pollution

- Lighting can affect breeding cycle and foraging behavior of wildlife in both urban and rural areas
- Light at night can lead to a significant decrease in melatonin levels
 - Melatonin level change can disturb circadian clock inside our body, causing diseases including depression, insomnia, cardiovascular disease, and cancer



1.6.2 Healthcare

Noise pollution

- Some noise sources in transportation systems can produce loud noise
- Long term or a single traumatic experience of loud noise can cause permanent hearing loss
- Exposure to traffic noise at night increases risk for artery disease
 - Research show noise from railroad cause cardiovascular effects to surrounding residents
 - Roadway noise can lead to elevated blood pressure



1.6.3 Humanism

- **Aged groups**
- **Disabled groups**



1.6.3 Humanism

Aged groups

- Proportion of elderly drivers increases
- Muscles may get weakened
 - Harder to turn the steering wheel, step on pedals or look back
- Eyesight and hearing change
 - Harder to see traffic signs or hearing horns
- React slower
 - Longer breaking distance
 - Longer reaction time to emergencies
- Medicines' side effects
 - Drowsy or lightheaded

1.6.3 Humanism

Disabled groups

More requirements

- People with disabilities need to meet necessary medical requirements
- Vehicles need to be modified for disabled drivers
 - Devices: seat belt, pedals, steering wheel, gear shift, hand brake and other components need to meet specific physical condition of driver
 - Parking: disabled parking spots require more space to load the wheelchair



By Joanbanjo - Own work, CC BY-SA 4.0,
<https://commons.wikimedia.org/w/index.php?curid=53547494>



1.6.3 Humanism

Disabled groups

Economic opportunities

- Limited transportation options of disabled people reduce their economic opportunities, causing isolation, depression, and a lower life quality
 - It is estimated that mitigating transportation obstacles for disabled would provide 2 million employ opportunities and save 19 billion dollars annually in healthcare expenditures[1]
- New technology (autonomous vehicles, ...) may provide great help for disabled drivers

[1] Claypool, Henry, Amitai Bin-Nun, and Jeffrey Gerlach. 2017. Self-Driving Cars: The Impact on People with Disabilities. Boston, MA: Ruderman Family Foundation.



Summary

In this part, we studied **environmental challenges**, including air, water, land and noise pollution as well as biodiversity issue.

Then we focused on the **health problems** that resulted from these challenges. Finally we talked about **humanism** mainly focusing on aged disabled groups.

In the next part, we will be focusing on the **Limitation of Development for Transportation System.**

1.7 Limitation of Development for Transportation System

Jiarui Zhang



1.7.1 Economic Limitation

Source:

<https://www.artba.org/about/faq/#:~:text=Construct%20a%20new%204%2Dlane,per%20mile%20in%20urban%20areas>

<https://reason.org/policy-study/23rd-annual-highway-report/maintenance-disbursements-per-mile/>

Cost of high way

A new four-line highway

\$4---\$6 million per mile in rural areas

\$8---10 million per mile in urban areas

Around **\$7 million** per mile in rural areas

A new six-line highway

Around **\$11 million or more per mile** in urban areas

Maintenance: On a per-mile basis, **maintenance disbursements** averaged about **\$28,020 (2015)** per state, up 7.8% from **\$25,996** in 2013. In total, Maintenance disbursements comprise about **15.7%** of total disbursements, totaling **\$22.81 billion** in 2015, about **7.6%** more than in 2013 (**\$21.19 billion**)



1.7.1 Economic Limitation

Cost of a airport: To build an airport costs **USD 30 million per 3 km runaway**, as well as **USD 500 per square meter (SQM)** for an airport passenger terminal.

Maintenance fee: On average of fuel cost, variable cost, total fixed cost, and annual budget, it costs **\$19,253.37 per hour** to maintain a **Boeing 747**.

Source:

[1] <https://www.scmo.net/faq/2019/8/9/how-much-does-it-cost-to-build-an-airport>

[2] <https://www.aircraftcostcalculator.com/AircraftOperatingCosts/380/Boeing+747-400>

1.7.1 Economic Limitation

Cost of Railway: U.S. freight railroads spent over **\$660 billion** in maintenance and capital expenditures between **1980 and 2017**, averaging **40 cents per revenue dollar**. In **2015**, railroad capital and maintenance expenditures **exceeded \$30 billion**, while in **2017** there was approximately **\$24.8 billion** in spending on capital and maintenance. **Class I railroads'** total spending on infrastructure and equipment remained consistent at roughly **\$20-\$22 billion per year** between **1983 and 2011**. **Between 2011 and 2017**, spending on infrastructure and equipment has increased to **an average of nearly \$28 billion per year**.

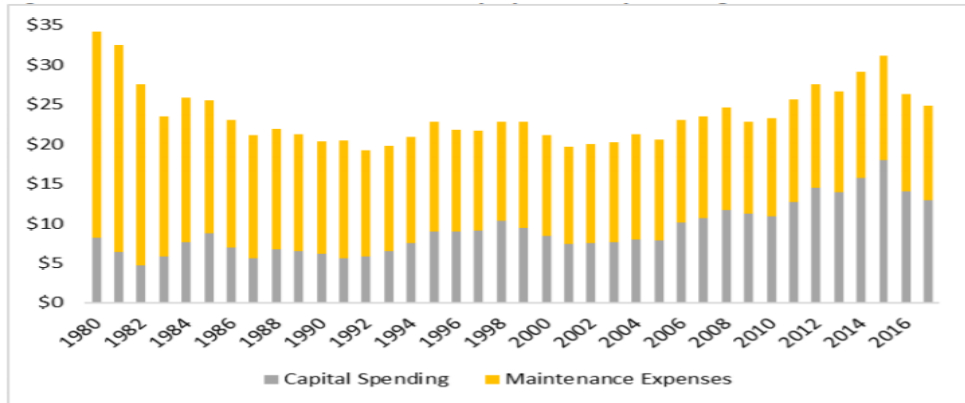

Source: Economic and Fiscal Impact Analysis of Class I Railroads in 2017

1.7.2 Physical and Environmental Limitations

It is difficult to construct transportation infrastructures in high altitude areas: Take famous Qinghai-Tibet railway as an example, the average altitude of Qinghai-Tibet railway is above **4000 meters**, as a result, factors like permafrost areas, altitude sickness, and environmental protection are unavoidable. These difficulties take construction teams **22 years and 33billion RMB** in total to finish this masterpiece.



Source: Environmental impact assessment and environmental audit in large-scale public infrastructure construction: the case of the Qinghai-Tibet railway

1.7.2 Physical and Environmental Limitations

Furthermore, according to the data, there are more than **100,000 protected areas worldwide**, comprising **about 12 percent of the Earth' s surface**, which may greatly impact the construction process of transportation infrastructures.



Source: Protected areas reduce poaching but not overall anthropogenic mortality of North American mammals

1.7.2 Physical and Environmental Limitations

Nail Houses



1.7.2 Physical and Environmental Limitations

Nail Houses



1.7.2 Physical and Environmental Limitations





1.7.3 Climatic Influence

Hot summer is also a huge threat for Road

1. Hot weather can cause small **cracks and potholes** on road surface.
2. In rainy climates, summer is a prime time **for big storms with wind, hail**, and other damaging issues. These cause the unexpected **erosion issues**.
3. And, during extremely hot days, **sunshine may totally melt the asphalt**.
4. The **fluctuation of temperatures** in a day is another great threat. **High temperatures during the day** may cause the pavement to expand; while the **cold temperature during the night** may cause the pavement to contract; constantly under such situations may even **cause pavement curls**.

<https://www.ejprescott.com/blog/how-seasonal-erosion-affects-roadway-erosion>

<https://prioritypavingfranklin.com/2019/04/how-water-and-seasonal-changes-can-affect-asphalt-pavement/>

1.7.3 Climatic Influence

A network diagram in the background consisting of several grey and black circular nodes connected by thin black lines, forming a web-like structure.

Influences on **vehicles**:

As temperatures increase, many types of **vehicles can overheat**, and **tires will deteriorate more quickly**.

Influences on **railroads**:

High temperatures cause **rail tracks to expand and buckle**. More frequent and severe heat waves may **require track repairs or speed restrictions to avoid derailments**. Heavy precipitation could also lead to **delays and disruption**, and **tropical storms and hurricanes** can also **flood or leave debris on railways**, disrupting rail travel and freight transport.

Source: Potential impacts of climate change on US transportation: Special report 290

1.7.3 Climatic Influence

In addition, Impacts analyzed using a range of climate models indicate that the rail network may incur an increase in **delay-minute** costs over typical historic costs of **between \$25 and \$45 billion cumulatively through 2100** under a **low greenhouse gas emissions** future, and **between \$35 and \$60 billion** under a **high emission scenario**.



Impacts of climate change on operation of the US rail network



1.7.3 Climatic Influence

Influences on air travel

Periods of extreme heat or cold can affect aircraft performance and may cause airplanes to face cargo restrictions, flight delays, and cancellations. And according to the data, Since the late 2000s, flight delay has become an increasingly serious problem and has been spreading in China. **Flight on-time performance decreased to 68.33% in 2015 from 81.48% in 2006**, according to the Civil Aviation Administration of China (CAAC) reports . Furthermore, in 2013, the results showed that the **total indirect impact of flight delays** on China was **¥ 350.71 billion**.



Source: An empirical study on the indirect impact of flight delay on China's economy

1.7.3 Climatic Influence

Influences on ships and sea lanes

Changes in precipitation can affect shipping in many ways. **Flooding could close shipping channels, and increased runoff** from extreme precipitation events could cause **silt and debris to build up**, leading to **shallower and less accessible channels**. And In areas experiencing **increasing drought**, water levels could periodically decrease, limiting inland shipping on rivers.



1.7.4 Healthcare Constraints

The noise caused by vehicles may induce many physical and mental health.

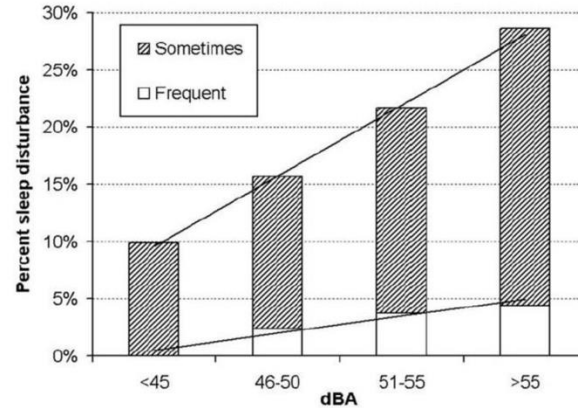
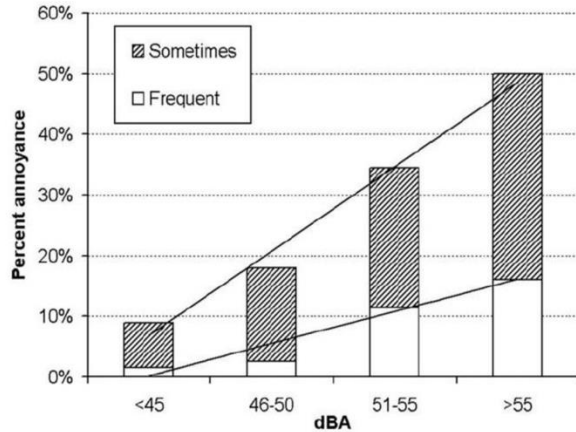

Road traffic noise and annoyance - An increasing environmental health problem

Summary

In this part, we understand that development of transportation system is actually constrained by many factors. In the past, it was human workforce helping us get over these challenges and difficulties. But nowadays, in a brand new era, we should pay attention to modern technologies, and use our wisdom to make transportation system thrive under huge stress.

PART 02

Current Transportation System and UV-Perspective

Development of transportation system, introduction to Universal Village perspective, and evaluation of current ITS through UV-perspective



2.1 Development of Transportation System

Jingyuan Chen



2.1 Development of Transportation System

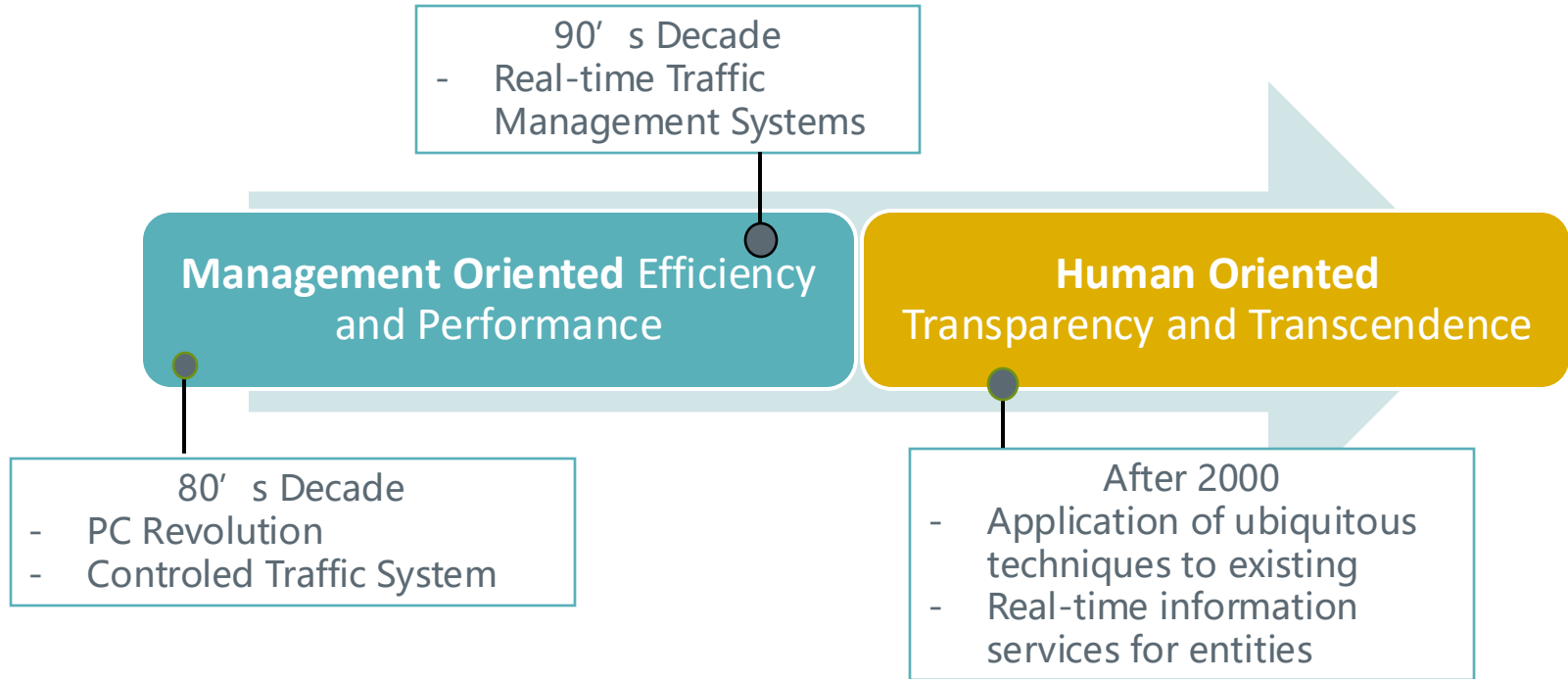

2.1 Development of Transportation System

Transportation Service Index and rising mobility need:

A index to measures the movement of freight and passengers. created by the Bureau of Transportation Statistics (BTS)

Fig.1. shows the Transportation Service Index between 2009-2019 [1].

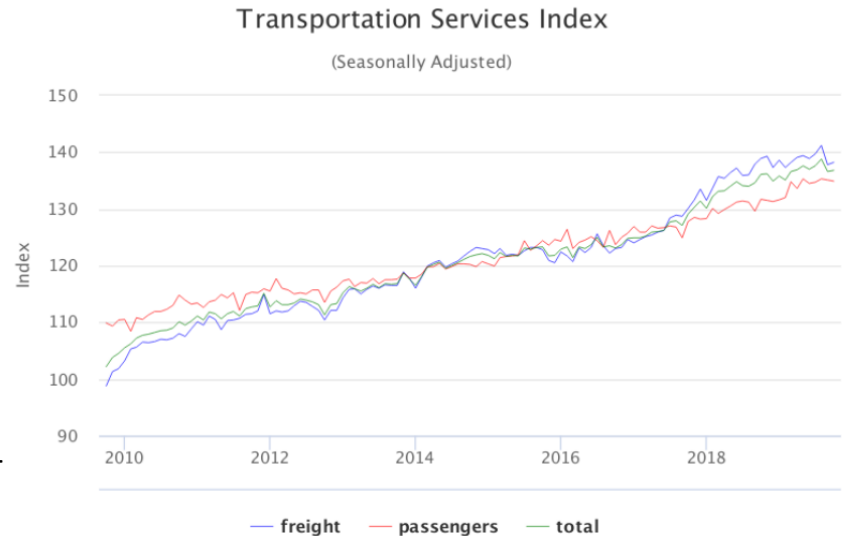

Fig. 1. Transportation Services Index(TSI),2009-2019



2.1.1 Transportation Modes--Air

Aviation:

- Backgrounds: Due to the urbanization process and the increasing human need for longer travel and communication distance, the request for air transport is surging.
- Types: The leading aviation service includes **scheduled air service** and **charter service**.
 - Scheduled air services: operate according to a pre-published schedule and can be reserved in advance.
 - A Charter air service: is an air service that is offered under specific circumstances. There are many different types of charter services, including Public Charters, Affinity Charters and Single Entity Charters.

2.1.1 Transportation Modes--Air

Annual Passengers on All U.S. Scheduled Airline Flights and facts behind the figure:

- Fig. 2. is the annual passengers on Airline Flight from 2003-2019 [3].
- The figure shows continued growth in air service demand.

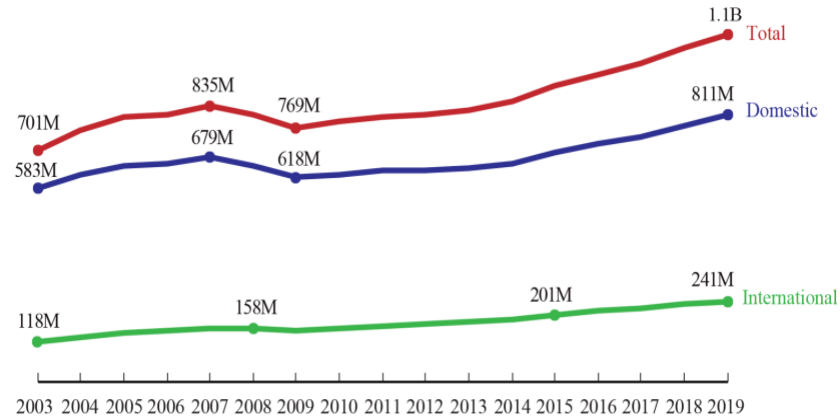

Fig. 2. Annual Passengers on All U.S. Scheduled Airline Flights (Domestic & International) and Foreign Airline Flights to and from the United States, 2003-2019



2.1.1 Transportation Modes--Waterborne

Waterborne:

- Background: The waterborne transport has two major types, which are **inland waterway** and **maritime**.
- Types:
 - Inlandwaterway transport: a competitive alternative to road and rail transport. In particular, it offers an environmentfriendly alternative in terms of both energy consumption and noise emissions. Its energy consumption per km/ton of transported goods is approximately 17% of that of road transport and 50 % of rail transport.

Besides, it alleviates the heavily loaded road network in highly populated regions. [4]

- Maritime transport: the dominating mean for freight transportation. It is also the cheapest transport mode, despite fluctuating exchange rates and a fee placed on top of freighting charges for carrier companies known as the currency adjustment factor(CAF) [5].

2.1.1 Transportation Modes--Waterborne

World seaborne trade by cargo type and facts behind the figure:

➤ Fig.3. Indicate the world seaborne trade by cargo type 1970-2018.

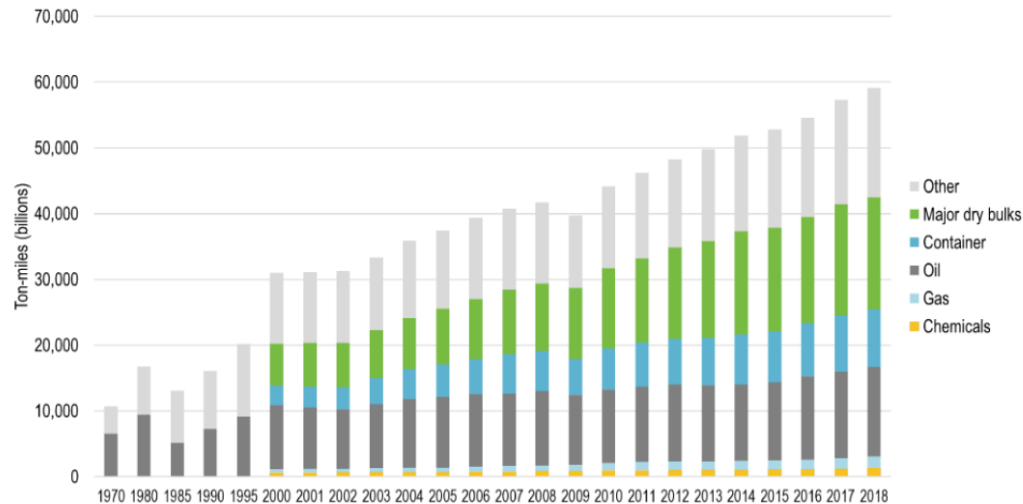

Fig. 3. World Seaborne Trade by Cargo Type, 1970-2018



2.1.1 Transportation Modes--Road

Road:

- Background: Road transports substantially include cars, bus, motorcycle, bicycle, which satisfy short-distance mobility demand.
- Trend and its characteristics: In recent years, road mode has experienced the most critical increase among other modes because of its inner characteristics: **flexibility**, **affordability** and **convenience**.
- Congestion Problem: The surging trend greatly contributes to the congestion of transportation networks.

2.1.1 Transportation Modes--Road

Automobile Production and facts behind the figure:

- Fig.4. shows the automobile production in selected countries(Japan,China,Germany,USA) during 1950-2018[2].
- According to the figure, China has experienced spectacular growth in automobile production, which reaches over 35% of the global production in 2018.

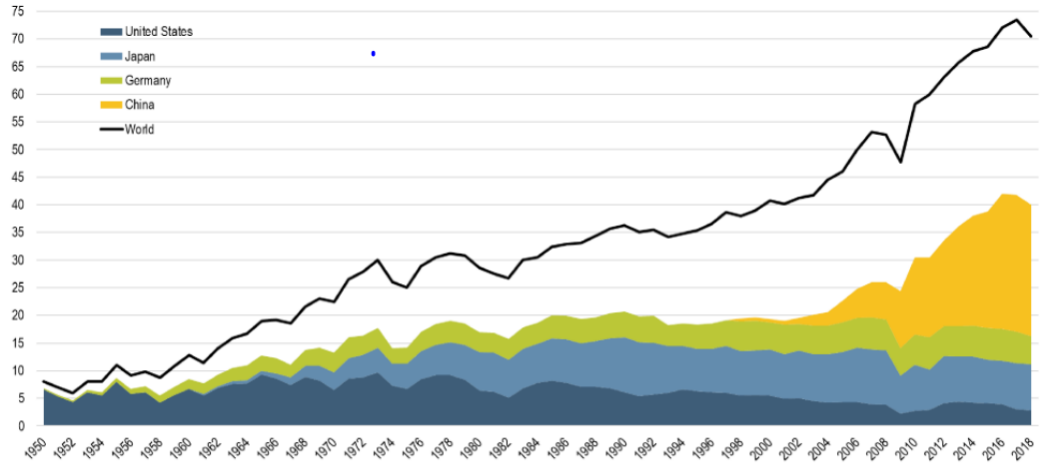

Fig. 4. Automobile Production, Selected Countries, 1950-2018



2.1.1 Transportation Modes--Rail

Rail:

- Background: Rail transport is rather **fast, stable** and **affordable** transportation means through rails for logistics and passengers.
- Trend of HSR:
 - Over the past ten years, High-speed rail(HSR),the fastest ground-based commercial transportation, has build transport networks between major high populated regions.
 - The fastest HSR, Shanghai Maglev Train, functioning at speed up to 430 km/h. China had built over 127000 km of railroads, which HSR makes up for 25000 km, account for 66.3% of the global HSR railroad.

2.1.1 Transportation Modes--Rail

Development of High-Speed Train Traffic and facts behind the figure:

- Fig. 5. shows the development of high-speed train traffic, 1964-2017. [2]
- Through all countries experienced a steady growth of HSR, China' s growth is rather rapid.

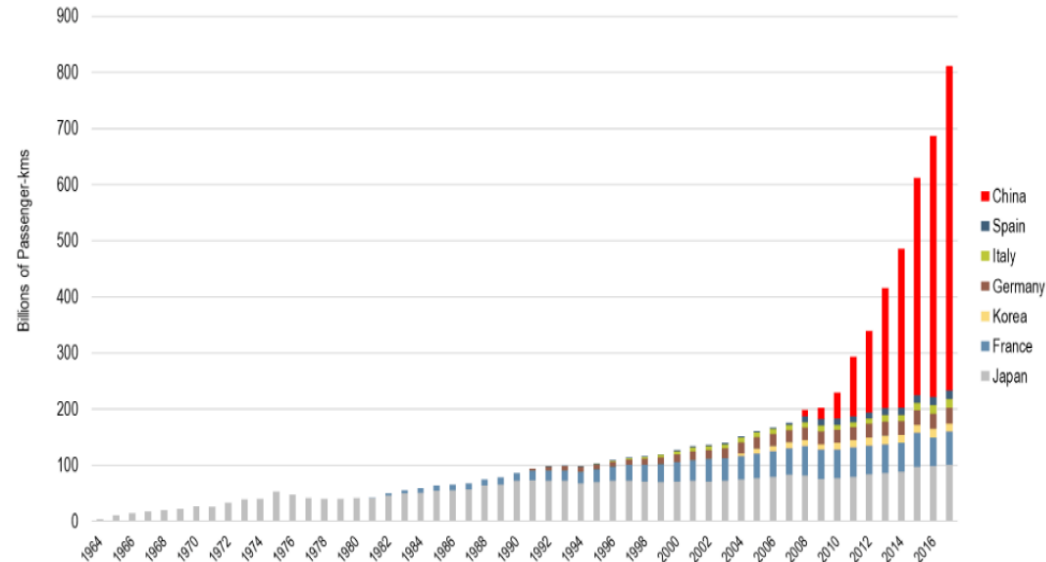
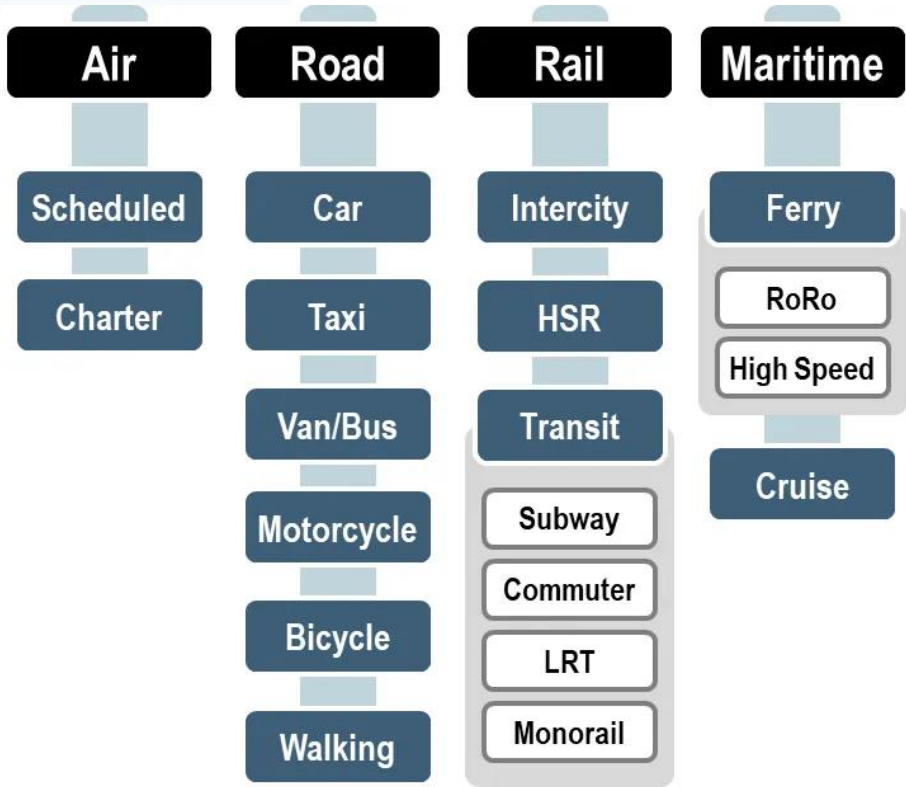

Fig. 5. Development of High-Speed Train Traffic, 1964-2017

2.1.2 Passenger Targeted Transportation

Passenger Orientated:

- Definition: the movement of passengers through four transportation modes road,rail,waterborne,aviation and new emerging modes such as scooters and segways.
- Passenger transport must consider these four general characteristics: **safety**, **time** and **efficiency**, and **growing expensive lifestyle**.



2.1.2 Passenger Targeted Transportation

Europe Passenger Transport Volume and Modal Split and facts behind the figure:

- Fig.6.shows Europe passenger transport volume and modal split,1995-2017. [6]
- The figure indicate that the passenger cars make up for 70.8% of all modals, and tram has experienced a steady increase as of 2017.

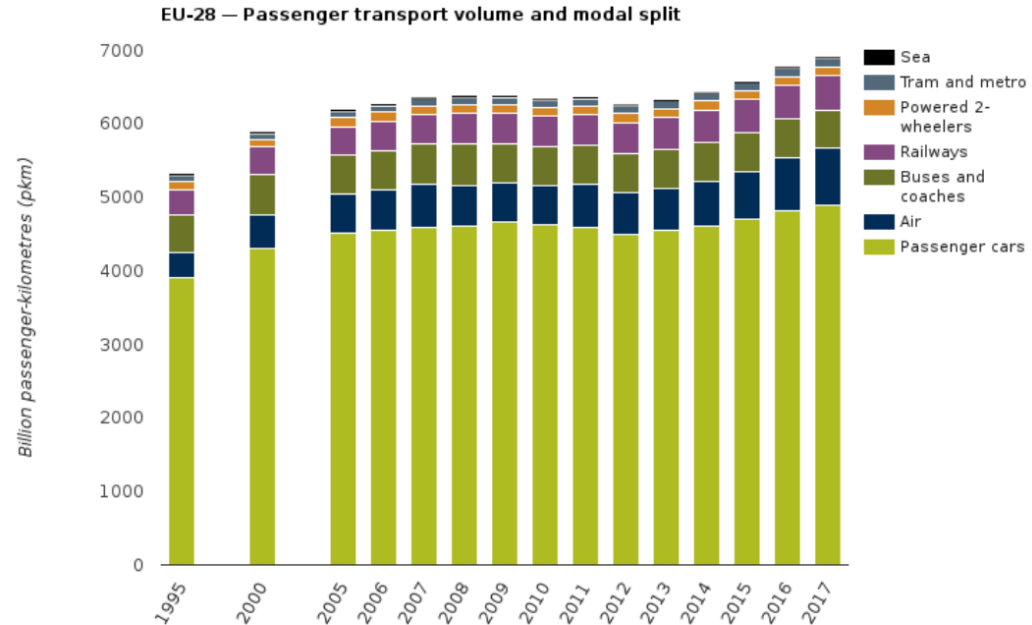

Fig. 6. Europe Passenger Transport Volume and Modal Split,1995-2017

2.1.2 Passenger Targeted Transportation

Modal Data (seasonally adjusted) of United State Included in Passenger Transportation Service Index and facts behind the figure:

- Fig.7. shows the modal data (seasonally adjusted) of the United States included in the passenger transportation service index during 2000-2020.[1]
- According to the figure, air revenue has been fast upgoing during the 2015-2019 year, indicating the evergrowing intercity and international demand.
- However, this rising trend experienced a drastic drop due to the influence of Covid-19.

Modal Data (seasonally adjusted) Included in Passenger Transportation Service Index

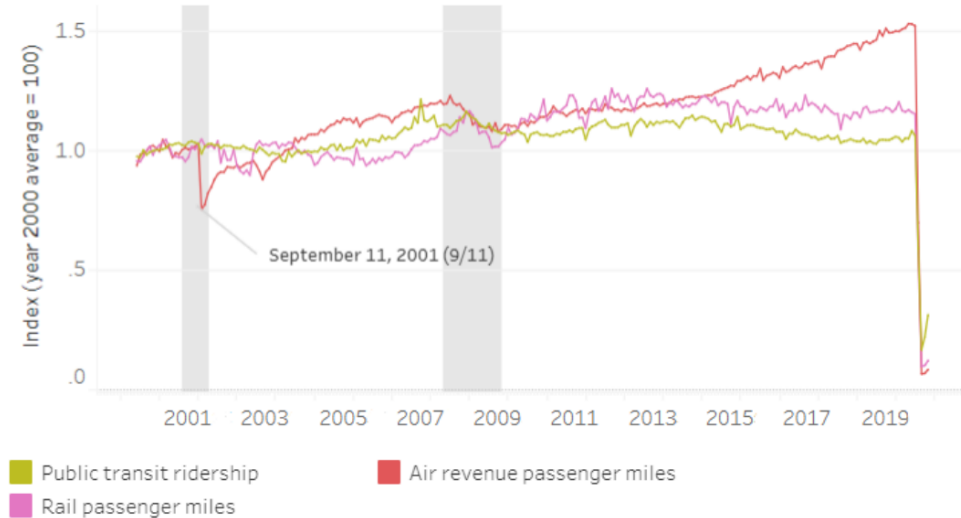
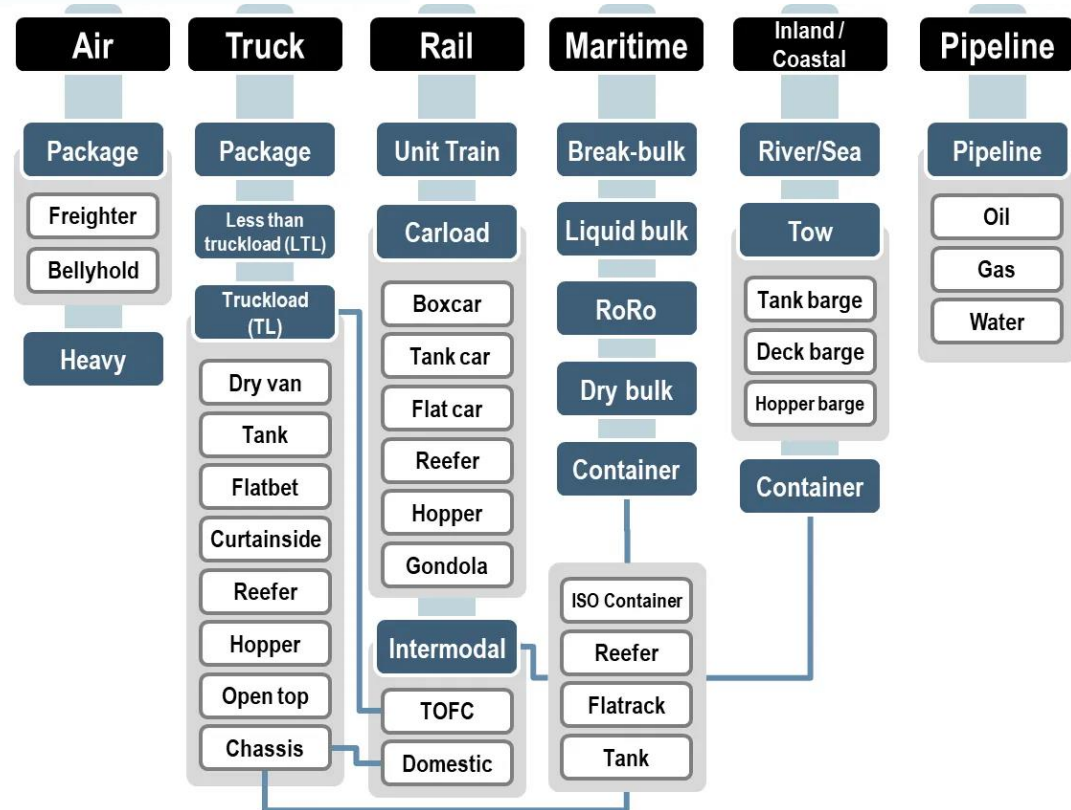

Fig. 7. Modal Data (seasonally adjusted) of United State Included in Passenger Transportation Service Index, 2000-2020

2.1.2 Logistics Targeted Transportation

Logistics Orientated:

- Definition: refers to the transport movement include freight.
- Special Feature: The mode of transport is usually dominated by the type of freight delivered. For instance, the waterborne mode does not opt for perishable goods; however, aviation does.
- Besides, a single modal can not meet the need for delivery. Thus intermodal, the combination of different modals, is commonly used in logistics transport.
- Unique transport modal: pipelines.



2.1.2 logistics Targeted Transportation

Europe Logistics Transport Volume and Modal Split and facts behind the figure:

➤ Fig.8. shows the Europe freight transport volume and modal split,1995-2017. [7]

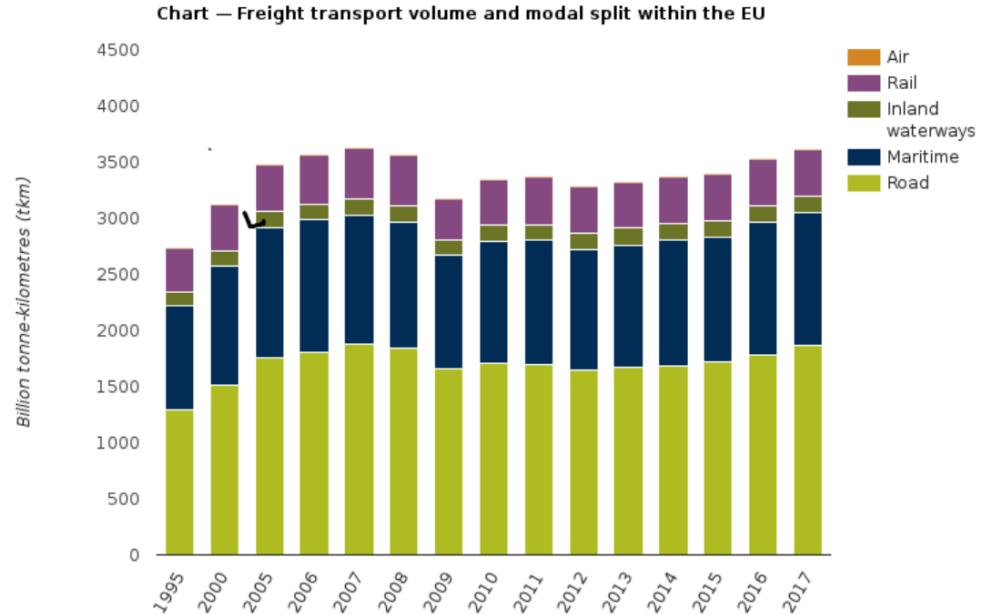

Fig. 8. Europe Freight Transport Volume and Modal Split,1995-2017

2.1.2 Logistics Targeted Transportation

Modal Data (seasonally adjusted) of United State Included in Logistics Transportation Service Index and facts behind the figure:

- Fig.9.shows the modal data (seasonally adjusted) of United State included in freight transportation services index,2000-2020.
- All types of modals has experienced a drastic fall due to the influence of Covid-19. .

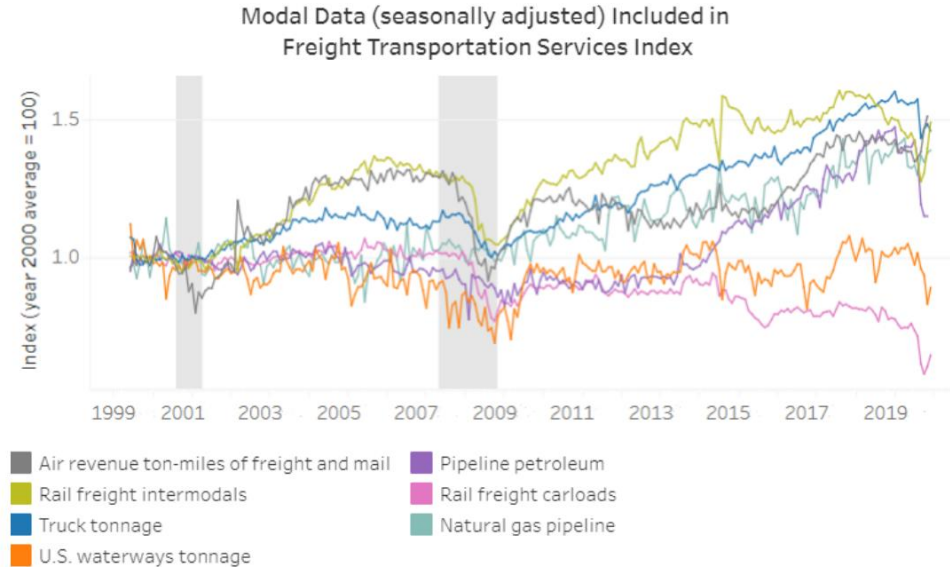

Fig. 9. Modal Data (seasonally adjusted) of United State Included in Freight Transportation Services Index, 2000-2020



Summary

In this part, we presented **development of transportation system** and different **transportation modes**.

In the next part, we will have an introduction of the **UV perspective on Intelligent Transportation System**.

2.2 Introduction to UV perspective on ITS

Yunpeng Fang



2.2 Introduction to UV perspective on Intelligent Transportation System

- Current challenge: The **rapid growth of vehicle ownership** leads to traffic congestion and the loss of public space, which seriously affects the quality of life of urban residents.

Figure 1. Vehicle Ownership and Per-Capita Income for USA, Germany, Japan, and South Korea, with an Illustrative Gompertz Function, 1960-2002

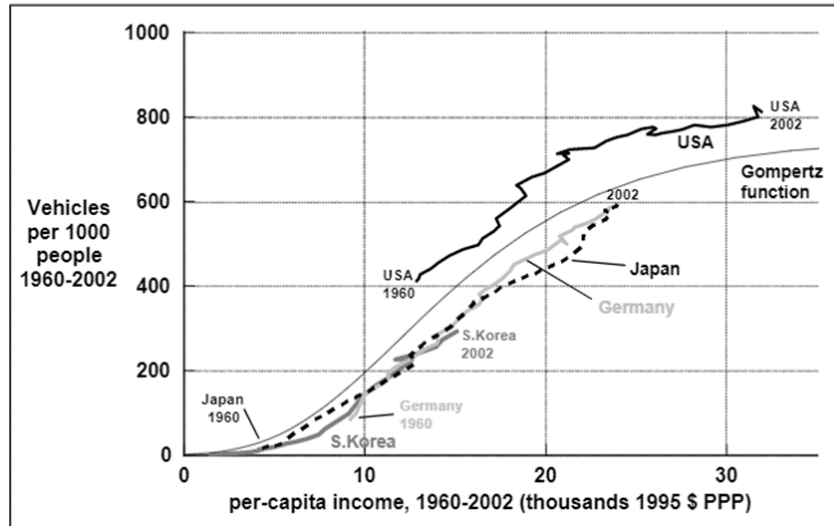
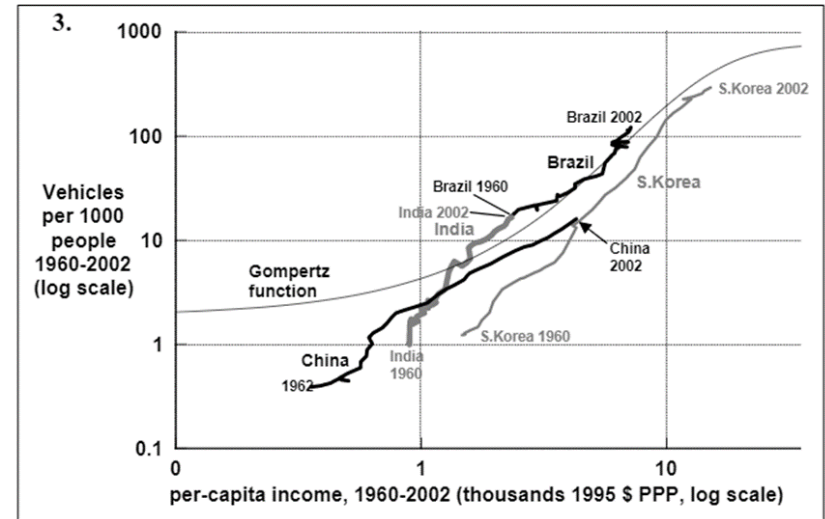

Figure 2. Vehicle Ownership and Per-capita Income for South Korea, Brazil, China, and India, with the Same Illustrative Gompertz Function, 1960-2002





2.2.1 UV elements & system framework

- **Final objective: Human-nature harmony**
- **Modeling: UV connectivity at different levels**
- **Information Flow**
 1. **interactions between UV subsystems**
 2. **closed feedback control loops**
 3. **Situ-remote hybrid for control signals**
- **Material Cycle**
- **Framework: system theory; signal coordination in time & spatial domain; data-fusion**

2.2.2 UV Perspective on ITS

Framework and Functionality

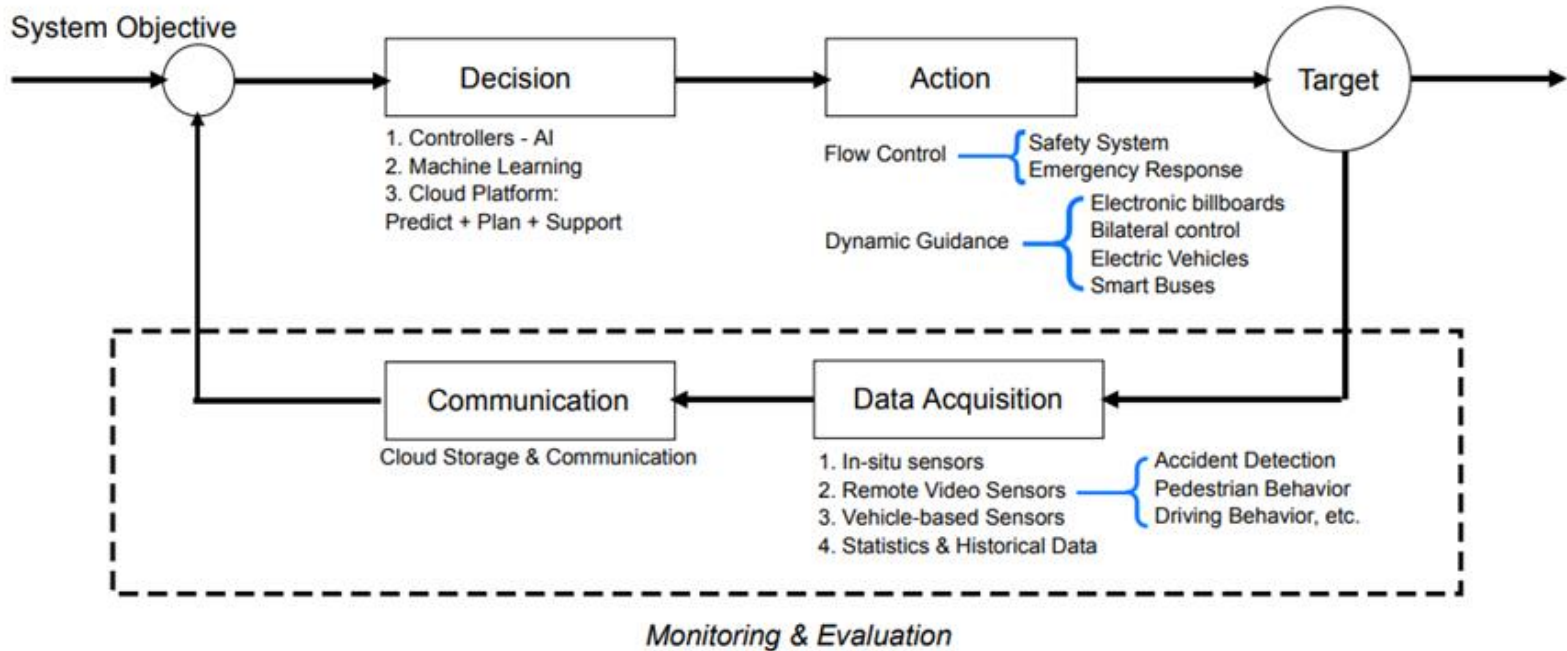

Fig. : Ideal Feedback Control for ITS



2.2.2 UV Perspective on ITS

ITS Objective :

- **Safety.** Feedback - Control Loops will predict accidents based on its elements to ensure traffic safety.
- **Meet the needs of citizens for fast and efficient travel.** ITS system will ensure the smoothness of travel based on data acquisition and overall coordination, avoiding accidents and vehicle convergence. On the macro level, it can shorten the waiting time for residents to travel and ensure the efficient operation of vehicles.
- **From the perspective of environmental protection,** ITS system will reduce exhaust emissions by coordinating the efficient operation of vehicles and reducing vehicle congestion. Meanwhile, the operation of more efficient public transportation system will also improve the operation efficiency of urban traffic while reducing environmental hazards.
- **With humanity,** ITS system will provide a smooth and efficient urban traffic service to ensure the pleasant travel experience of residents and prevent the occurrence of psychological problems such as road rage caused by traffic congestion.



Summary

In this part, we proposed **Universal Village perspective** on ITS. Faced with current challenges, we introduced the **ITS objective**, as well as the **UV framework and functionality**.

In the next part, we will focus on the **Evaluation of current ITS through UV-perspective**.

2.3 Evaluation of current ITS through UV-perspective

Lixin Xu

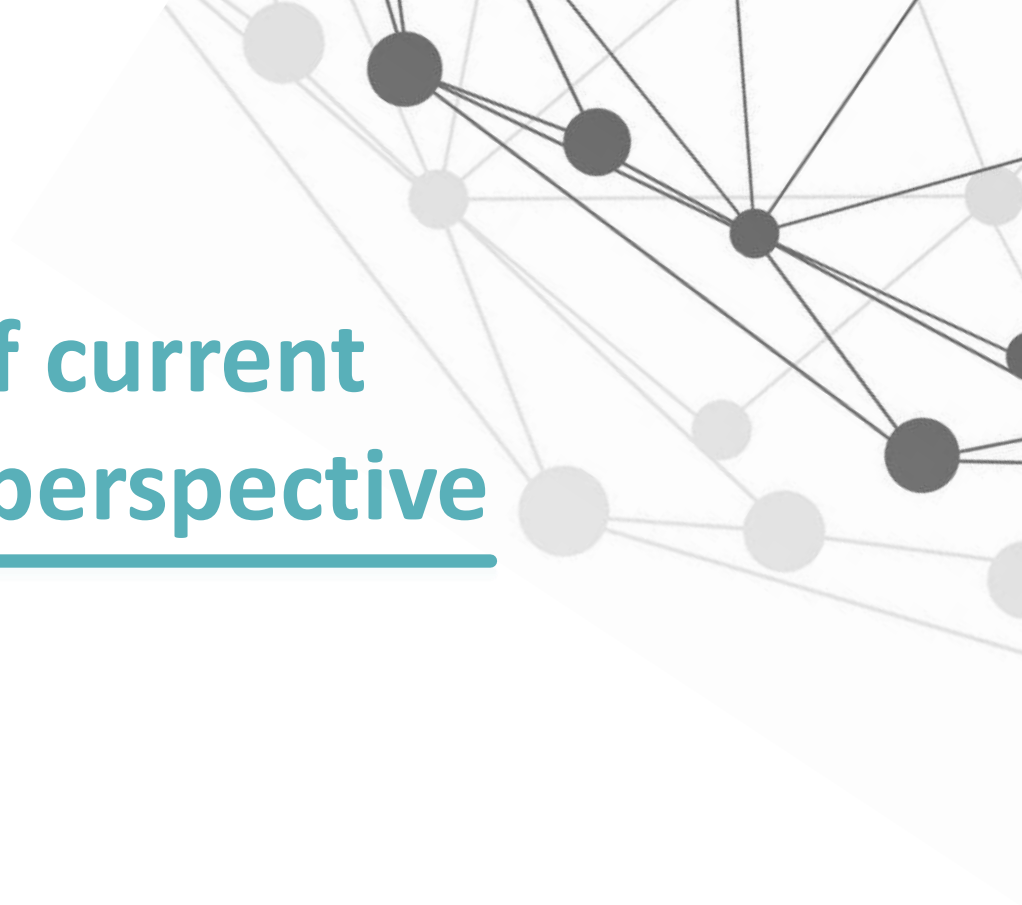

2.3.1 Sensing/Data Acquisition



2.3.1 Sensing/Data Acquisition

➤ Vehicle-based sensors

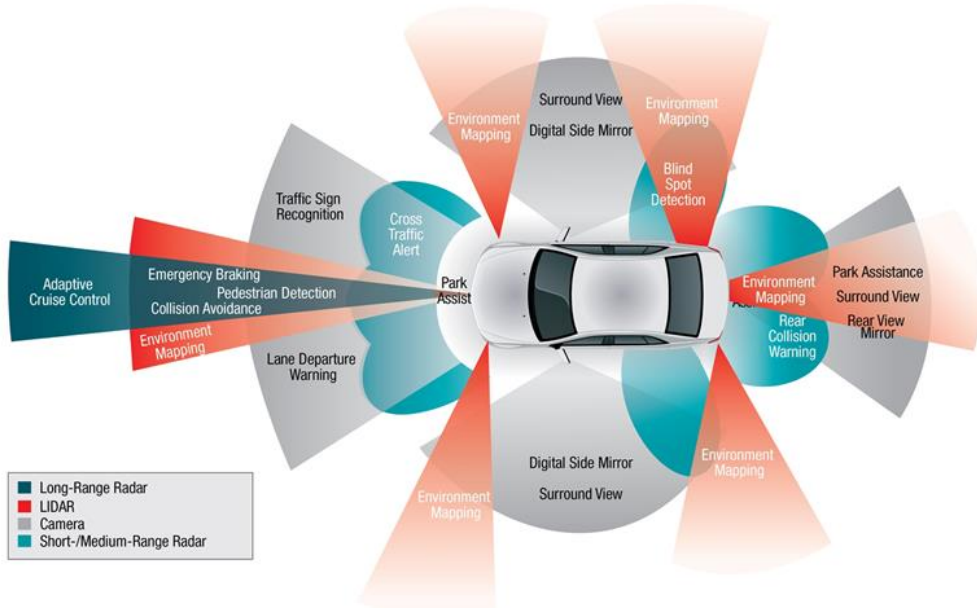

LIDAR: Stands for Light Detection and Ranging, is a remote sensing method that uses light in the form of a pulsed laser to measure ranges (variable distances) to the Earth.

Radar: Is a detection system that uses radio waves to determine the range, angle, or velocity of objects.

Camera: A camera is an important sensor in autonomous vehicles. It allows them to identify objects and people in the real world.

(*) Toward Data Science: How to make a vehicle autonomous

2.3.1 Sensing/Data Acquisition

Data Acquisition in ITS

Data acquisition also include the Information that helps drivers to make decisions



Source: AppRadioWorld

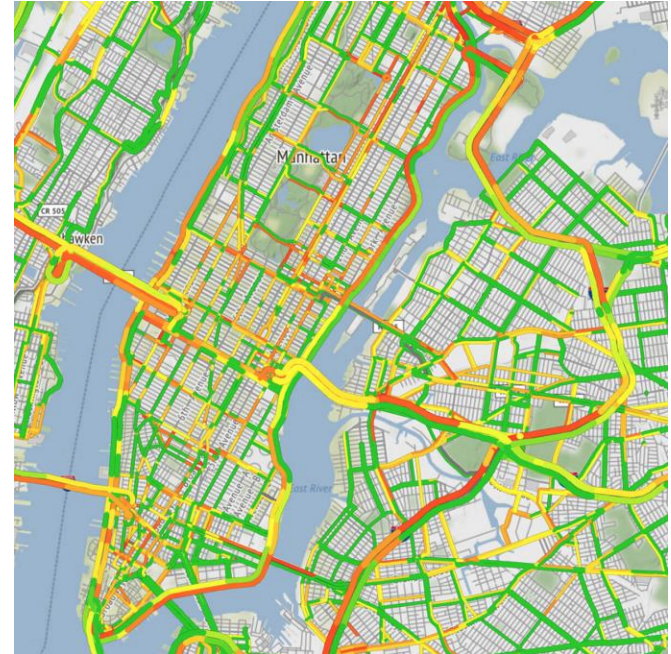

Source: tomtom

2.3.2 Communication



2.3.2 Communication

Communication components

Vehicle components

- wireless transceiver, embedded PC, GPS

Roadside components

- message sign, traffic light

Personal components

- smart phone, wearable smart device

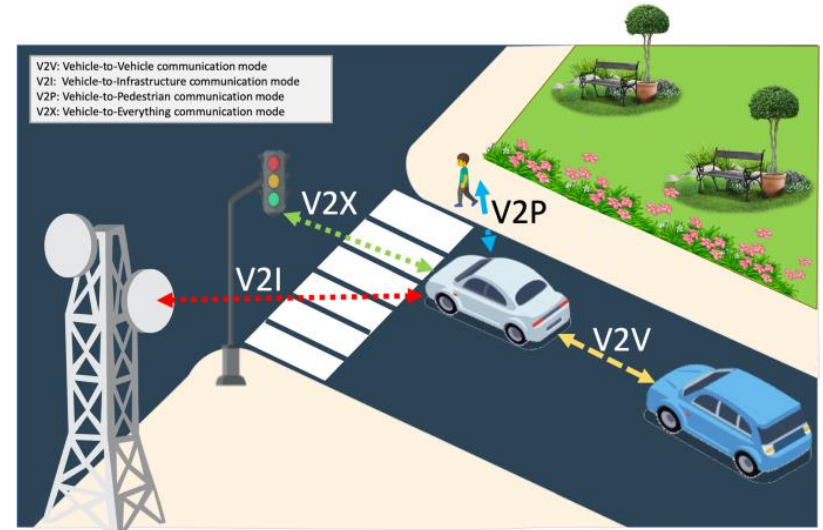

Courtesy “A tutorial survey on vehicle-to-vehicle communications”



2.3.2 Communication

The existing traffic management systems(TMSs)

- Lack granular data collection, incapability to aggregate masses of collected data, lack of complex and precise management systems.
- Main solution such as changing/adapting traffic light cycles, closing road lanes or intersections are not effective enough.

2.3.2 Communication

Smart phone applications

Passengers and drivers can get traffic information from various apps on mobile phones, including:

- road congestion condition.
- real time distance and estimated arriving time of a bus or a reserved taxi.
- nearby vacant parking spaces.

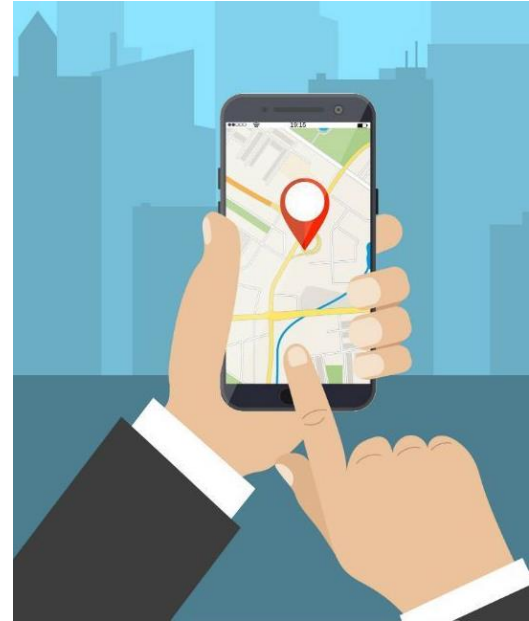

Taxi booking app Courtesy Space-O Technologies

2.3.2 Communication

Drivers/Vehicles and pedestrians

- Current communication between drivers and pedestrians such as eyes contact and body gestures are not explicit.
- Autonomous vehicles cannot recognize emergent event it did not learned before.
- Both effect are limited by poor visibility, occlusion, and response time.

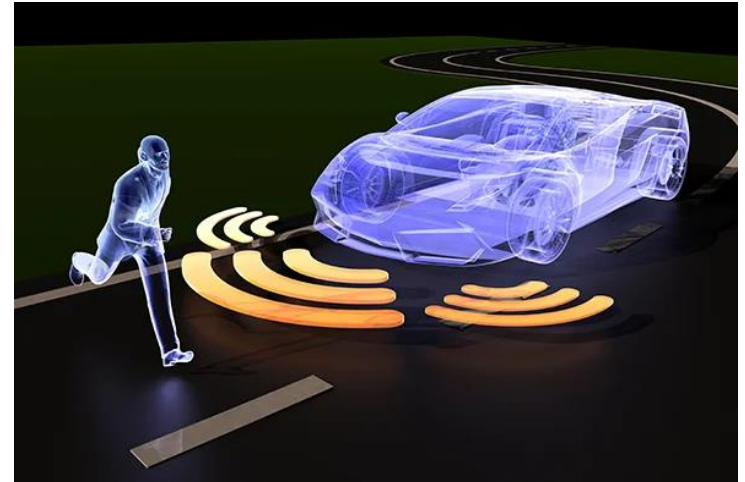

Courtesy Devrimb Getty Images



2.3.2 Communication

5G enable buses

The 5G network is a promising technology providing high speed, low latency and massive access wireless communication. Some 5G enable buses have been put to use in China, with:

- 5G and AI based passenger flow statistics systems and dangerous behavior monitoring by installing cameras to catch human face information at bus stations.

In the future:

- On-vehicle cameras monitoring drivers' safe operation.
- Fast payment by human face recognition.

2.3.2 Communication



This is a picture demonstrating a bus in Changsha, Hunan. The electronic plate at the back of the bus shows the blocked signal light, which greatly assists the decision making of the following driver, and it is a very nice implementation of communication in ITS.

2.3.3 Decision Making





2.3.3 Decision Making

Traditional decision making system

Traditionally, the control center or “decision making” system involves **a lot of controllers**, and each one is assigned to monitor different parts of a city. Manual operations **are no longer feasible** to monitor transportation patterns **in real time** due to the **rapidly increasing data quantity**.

AI, challenges and benefits

AI or machine learning and cloud platform are expected to process **a large amount of data** and help with **real-time “decision making.”** Currently, AI technology still faces many technical challenges, such as tracking individual targets with complicated backgrounds under all weather conditions, automatically identifying urgent situations, etc. AI technology **is alleviating the workload** of the human traffic management system and might even predict and prevent accidents.

2.3.4 Action





2.3.4.1 Existing Traffic Safety System

Vehicle safety systems

- Collision avoidance systems
- Driver monitoring systems
- Lane departure warning systems

Roadway safety systems

- Intersection collision avoidance systems
- Dynamic curve warning systems
- Wildlife detection systems
- Weather sensors

Incident and emergency response systems

- Automatic crash notification systems
- Emergency vehicle preemption systems



2.3.4.2 Existing Traffic Control System

Smart signal control systems

- Adjust red light duration dynamically

Electronic billboards

- display useful traffic information

Bilateral Control

- A system proposed at MIT to ensure a smooth traffic flow

Smart Buses

- Help alleviate traffic pressure and protect the environment

2.3.4.3 Existing Parking System

License plate recognition system

- Identify the vehicles

Parking guidance system

- Show the remaining parking spaces number
- Reverse car-searching system
 - Navigate user to the car in a large parking lot
- Parking payment system

Reverse parking assist system

- Sensor: camera, reversing radar
- Parking assistant system



Source:
<https://www.afzhan.com/news/detail/77595.html>

2.3.4.3 Existing Parking System



Source:
<http://www.brtn.cn/news/47hlm0ag6jg8qtaphmgdp6b9lge>

Intelligent robotic parking system in Beijing Daxing Airport



Summary

In this part, we evaluated ITS through **Universal Village perspective**. We have divided the whole process into four phases: **sensing**, **communication**, **decision making**, and **action**. These four phases form a closed feedback loop that ensures the whole system works properly.

In the next part, we will focus on Part 3, **Information Flow and Material Cycle**.

2.4 UV-oriented Solutions and Framework for Integration, Resilience, Inclusiveness and Sustainability

Lin Li



UV-oriented Framework

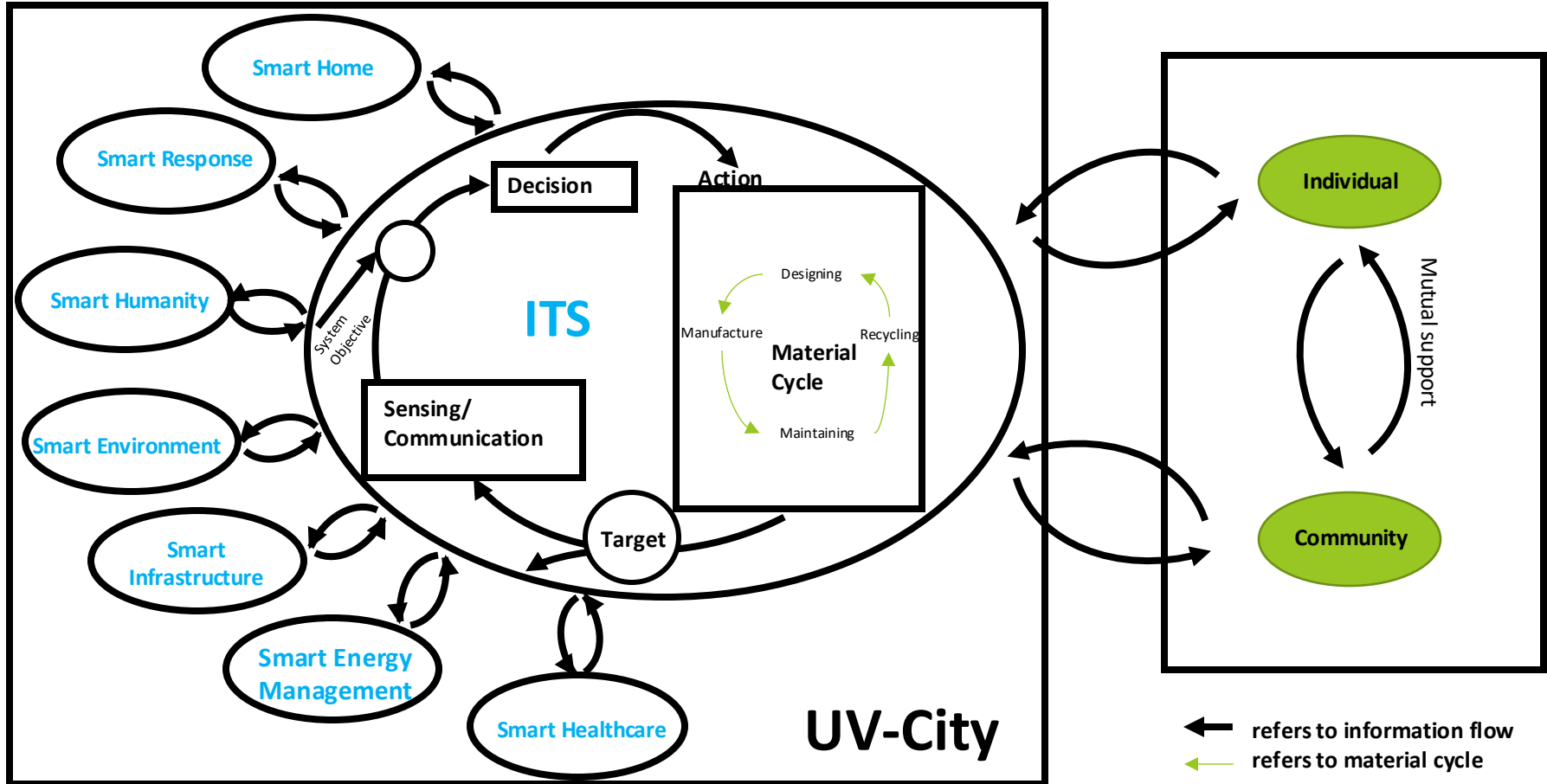

The information flow in ITS

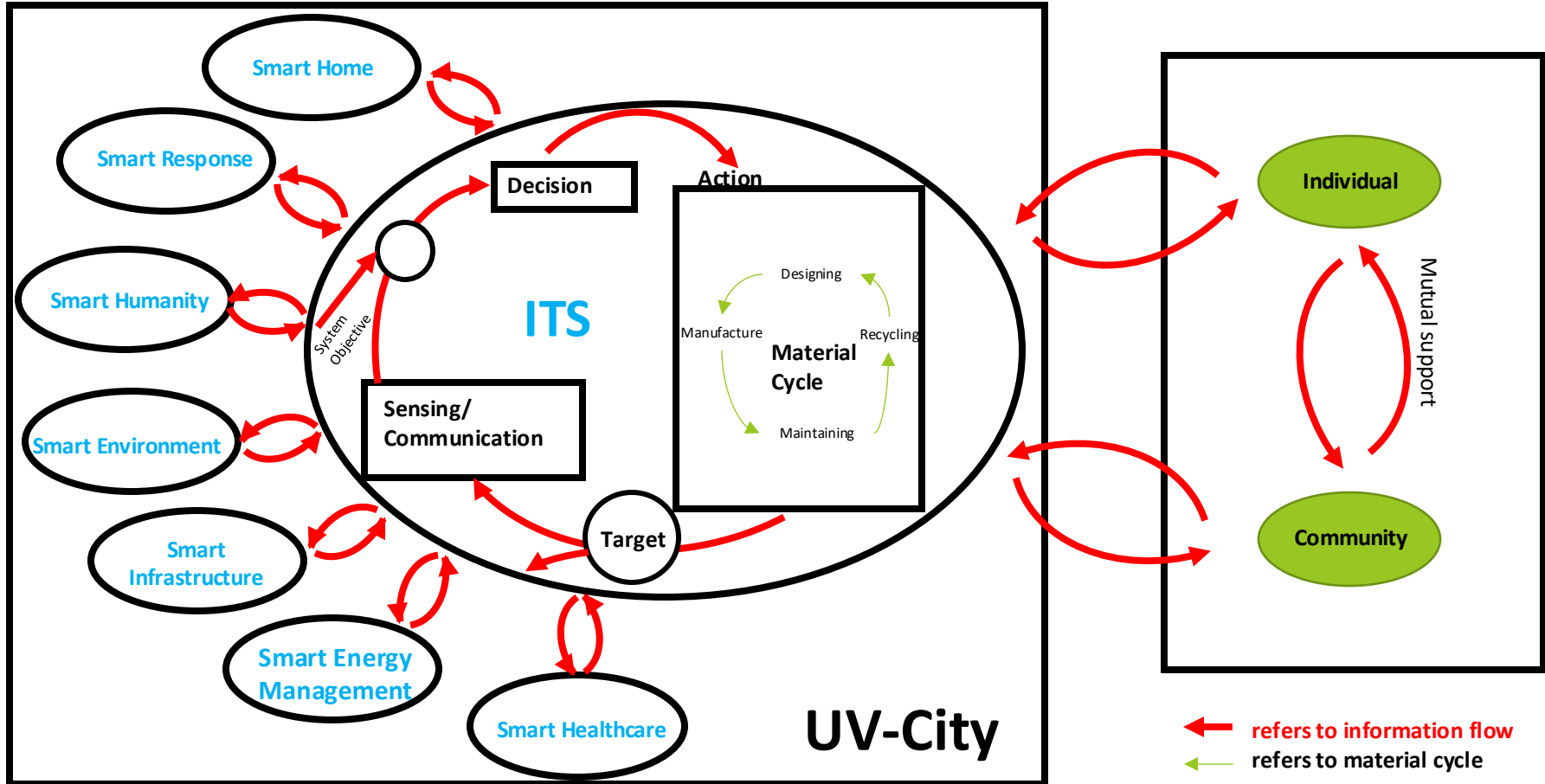

The information flow in ITS

- Interaction between ITS and Information system
- Automatic Adjustment Enabled by Closed Feedback Control Loop
- Proactive and Human-Involved Adjustment Enabled by Information Sharing
- Precise Prediction and Effective Management Enabled by Data Mining
- Current Requirement of Information System In ITS

- Information flow about mutual support and smart humanity
 - Open Data Policy, Data Anonymization and Encryption
 - Privacy protection

The information system and the feedback loop of ITS

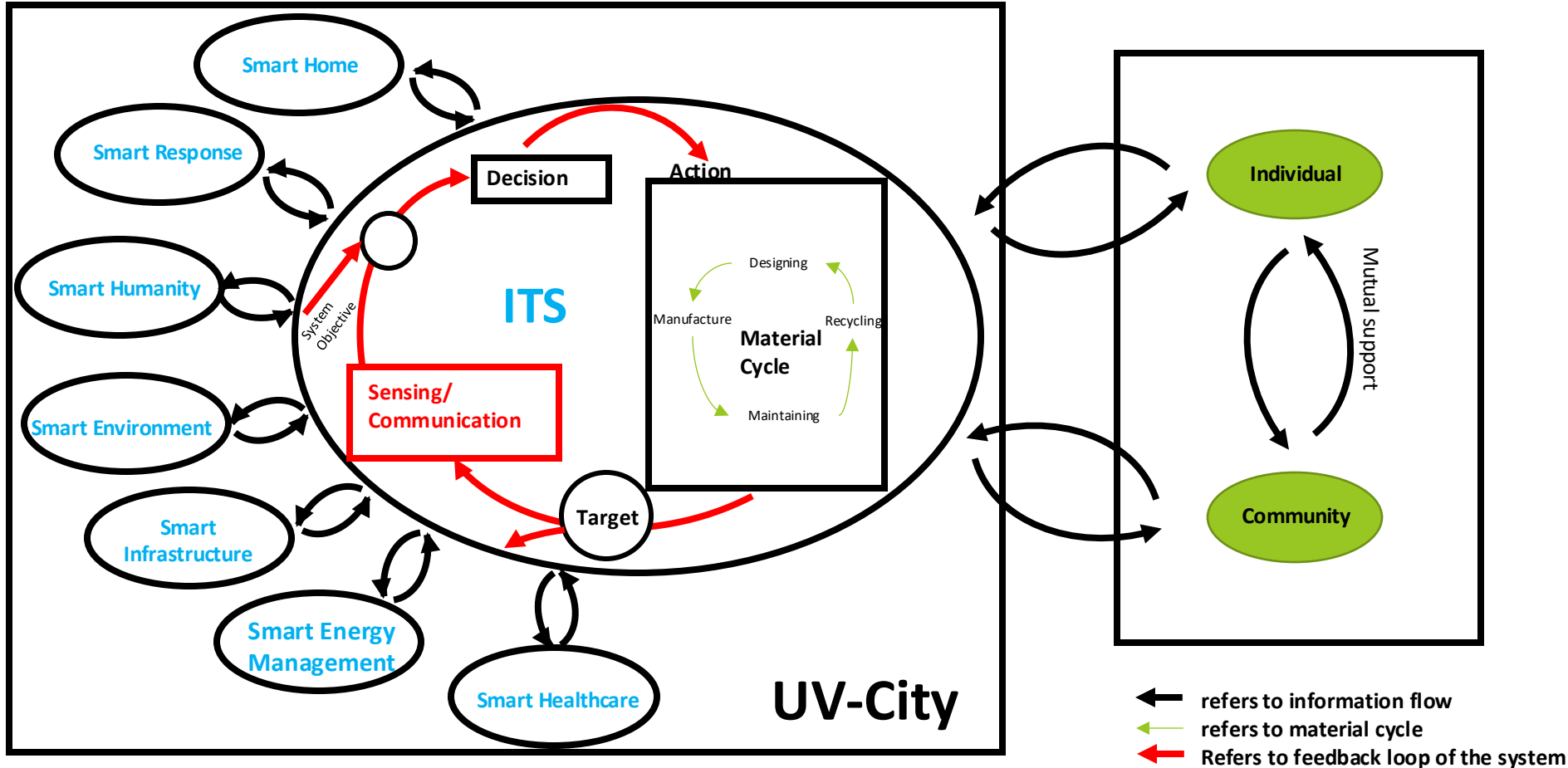

Information flow about mutual support and smart humanity

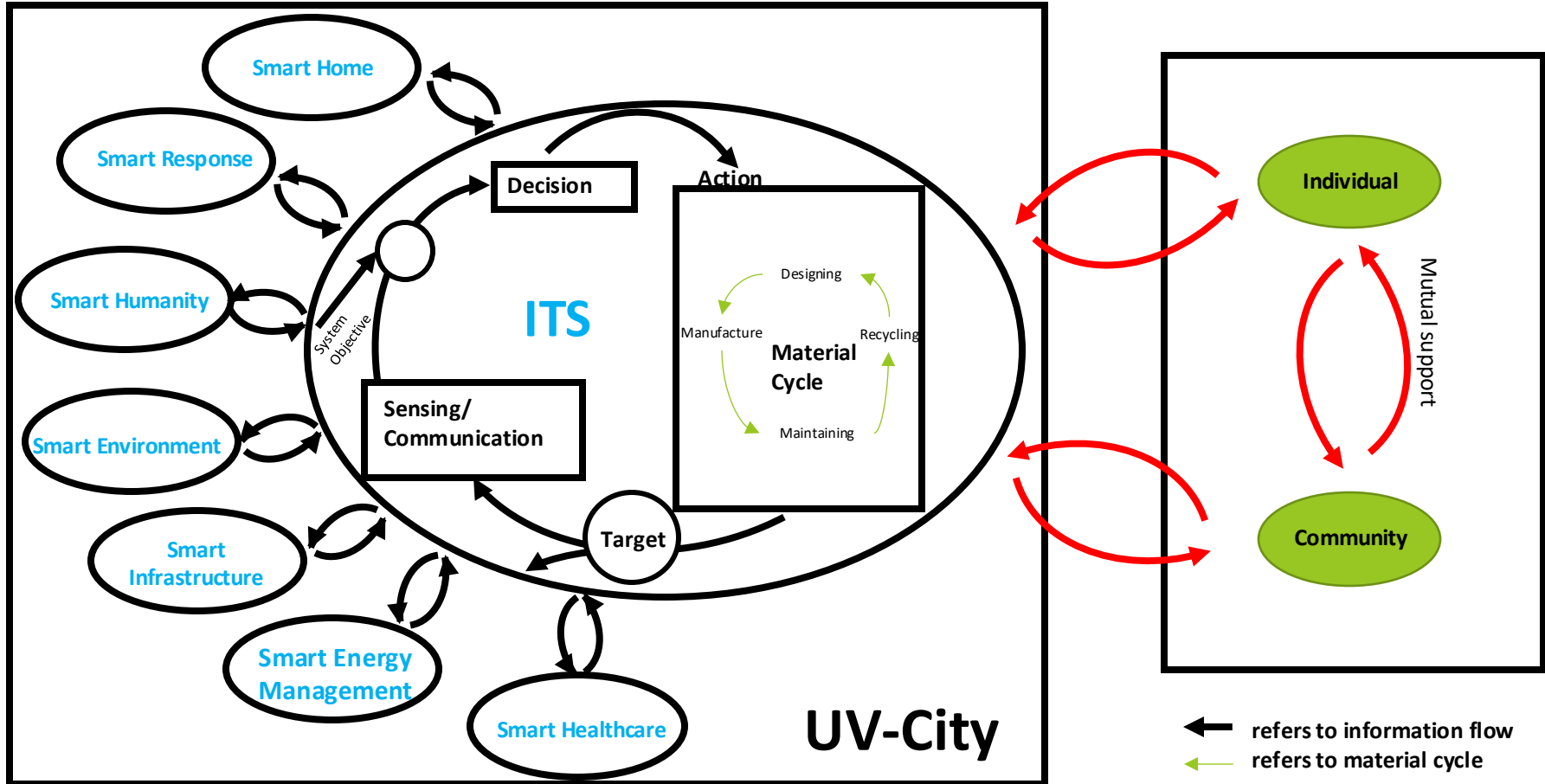

The Material Cycle in ITS

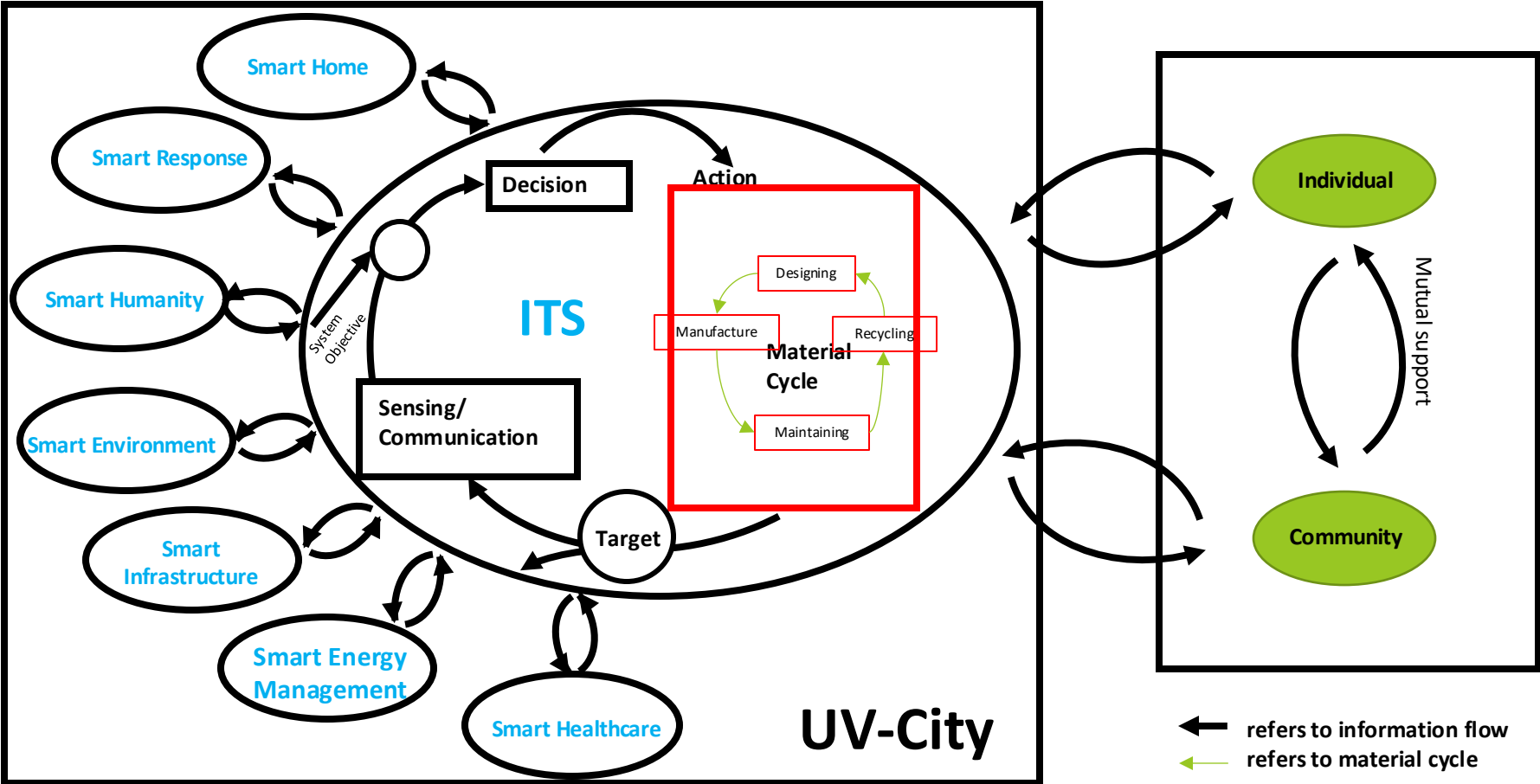

The Material Cycle in ITS

- Necessity and significance of material cycle in ITS.
- Current Material Cycle in ITS
- UV perspective on Material Cycle in ITS

Interactions with other UV city sub-systems

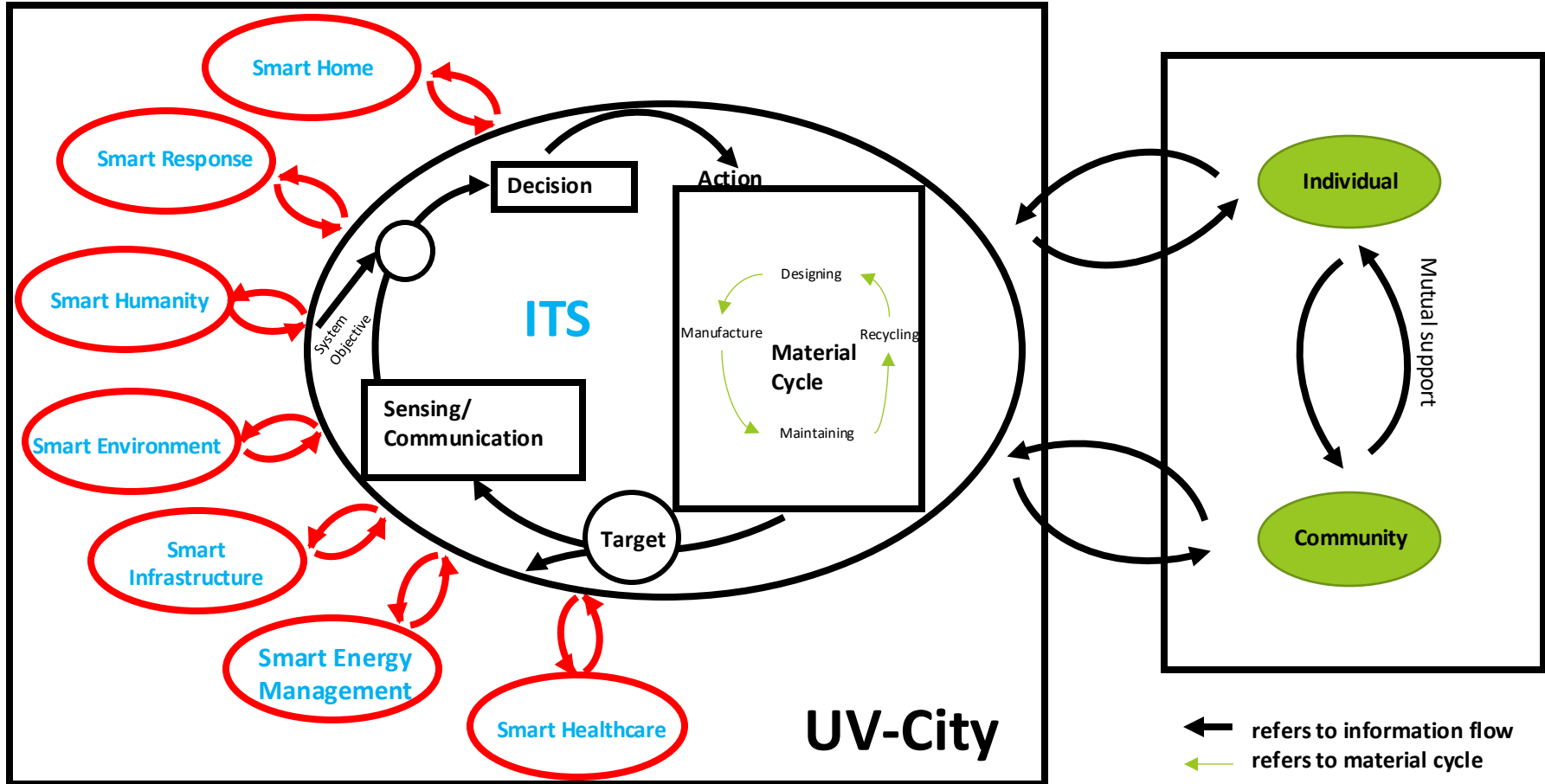

Interactions with other UV city sub-systems

Smart Home: Smart Parking...

Smart Response: Smart Monitoring System...

Smart Humanity: Driving behavior...

Smart Environment: Green Wave Speed

Smart Energy Management: Grids including Electrical Vehicles...

...

Lifestyle and Community in ITS

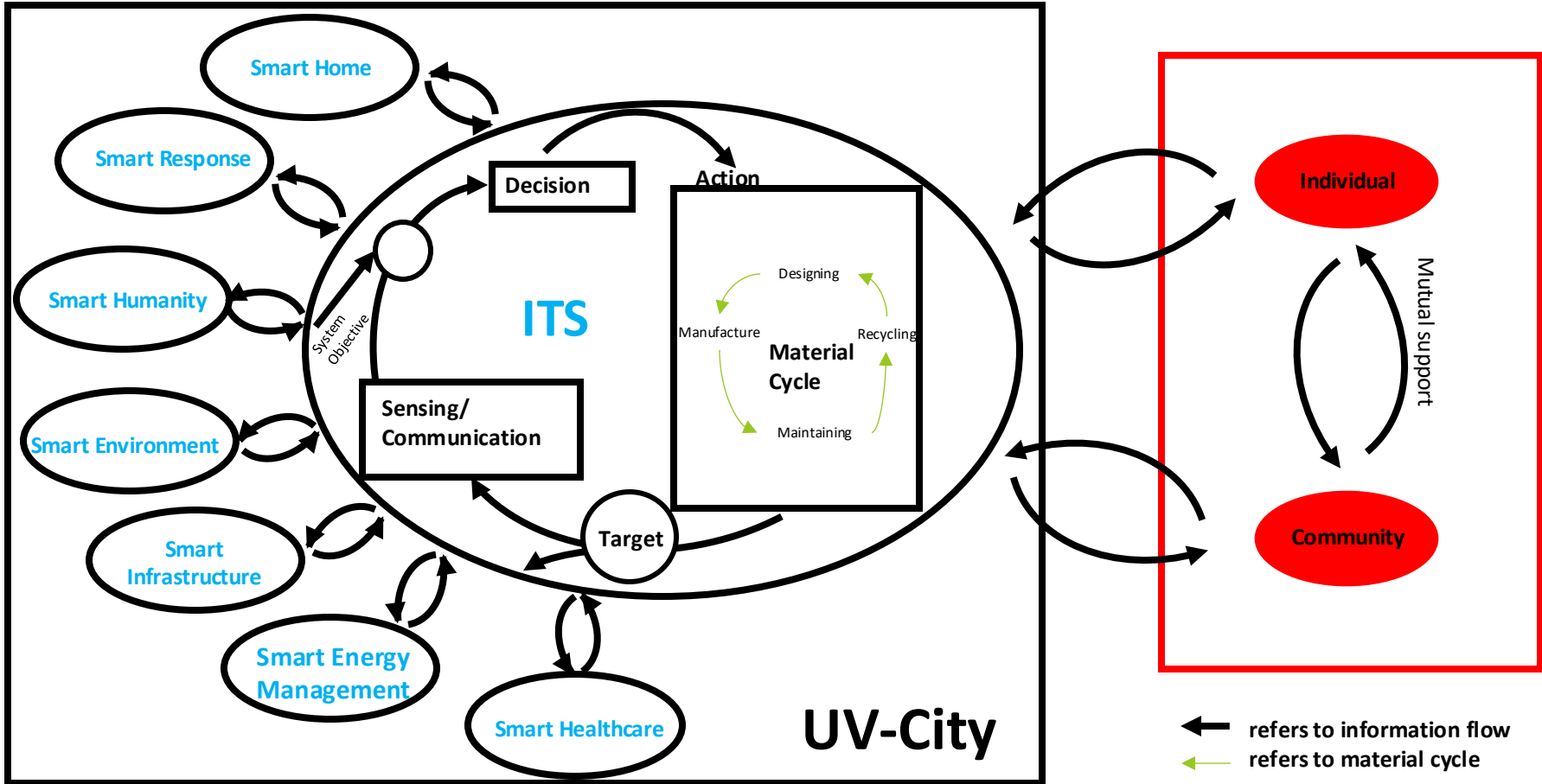

Lifestyle and Community in ITS

lifestyle

Choice of transportation

Fuel economy for cars

community

Community
at the national level

Focus on the elderly

UV-oriented Framework

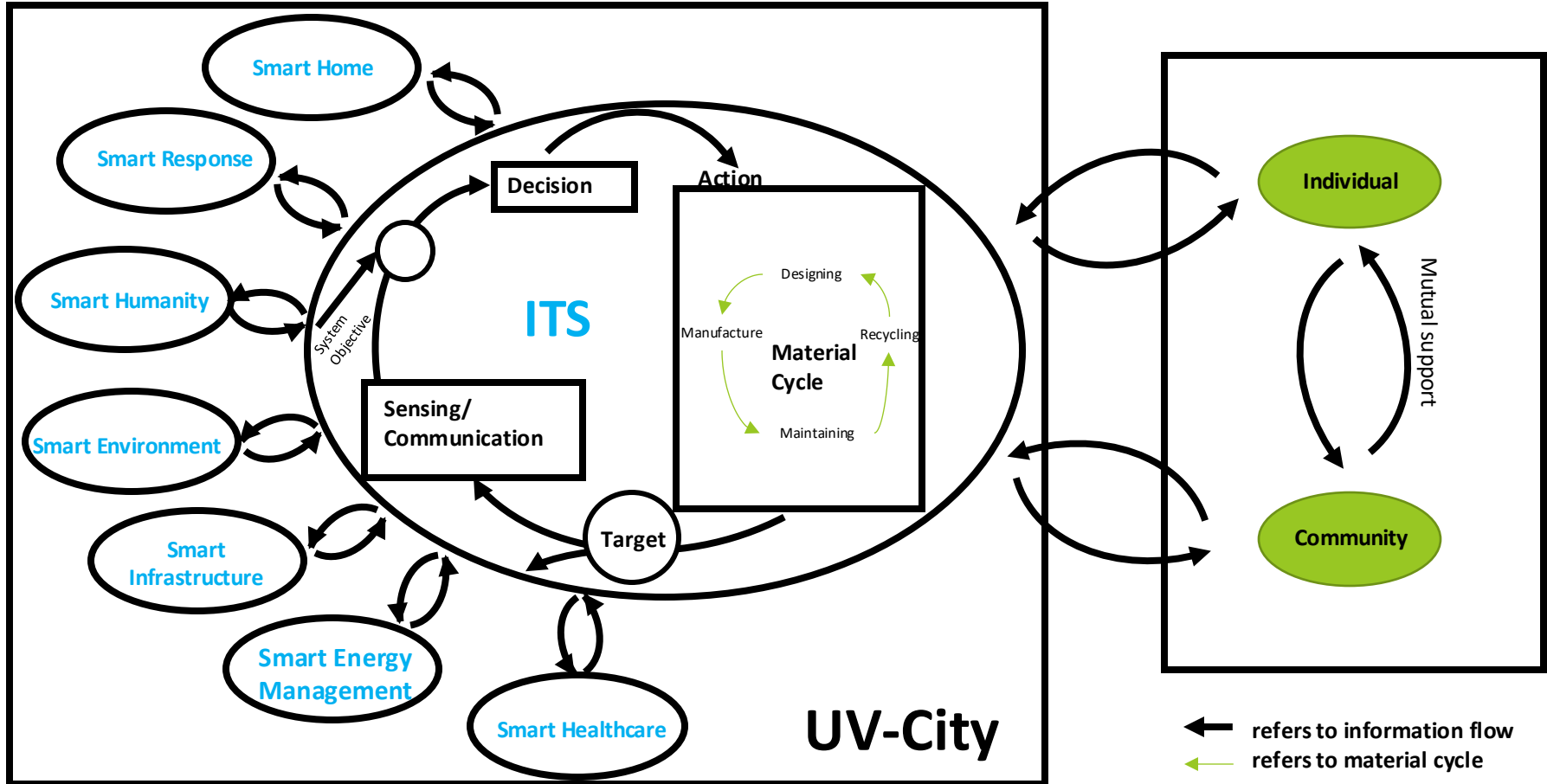

PART 03

Information Flow and Material Cycle

An in-depth discussion of information flow and material cycle in ITS



3.1 Information Flow

Yunpeng Fang



3.1 The information flow in ITS

Summary: Information flow plays a vital role in traffic management.

Traditional traffic systems still have problems in information acquisition, transmission and processing, etc.

The solution to these problems will depend on the application and development of information technology and the Internet of things.

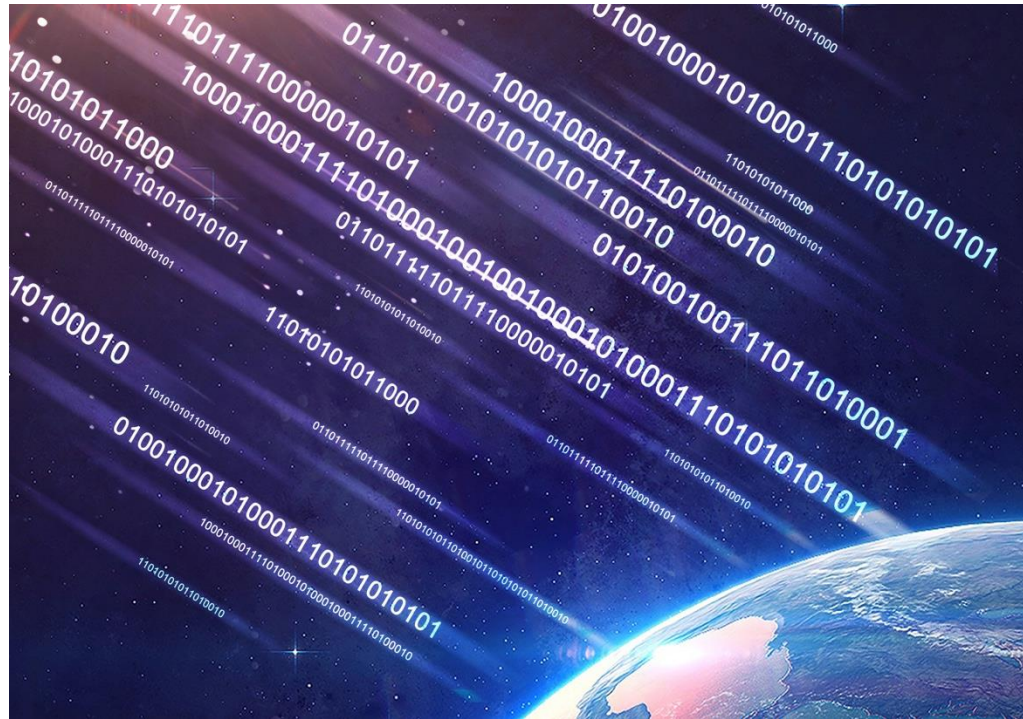

3.1.1 Interaction between ITS and Information system

top-down management approach that uses the IoT to secure communication between Vehicle and Infrastructure

A traffic-management system called dEASY takes a step forward in communication between vehicles and infrastructure

The figure on the right shows a three-layer traffic management model, including:

- Environment Sensing Lay
- Knowledge Generation and Distribution Lay
- Knowledge Consumption Lay

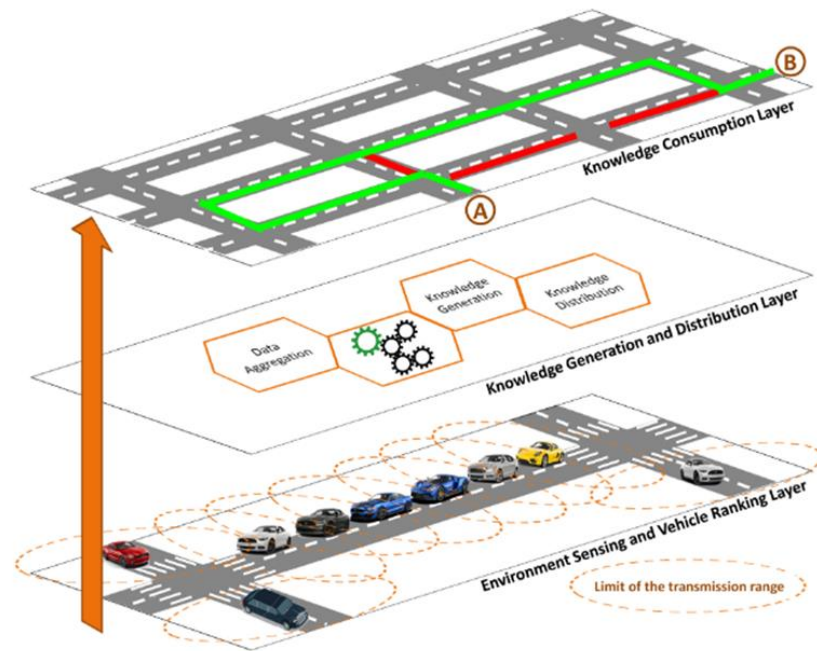

Fig. 1.The dEASY's three-layer system architecture

Akabane A T, Immich R, Bittencourt L F, et al. Towards a distributed and infrastructure-less vehicular traffic management system[J]. Computer Communications, 2020, 151: 306-319.

3.1.1 Interaction between ITS and Information system

top-down management approach that uses the IoT to secure communication between Vehicle and Infrastructure

Combining artificial intelligence with big data technology, a new real-time urban traffic management system has been designed.

The figure on the right shows a four-tier architecture for urban traffic management, including the environment sensing layer, communication layer, MEC server layer, and remote core cloud server (RCCS) layer.

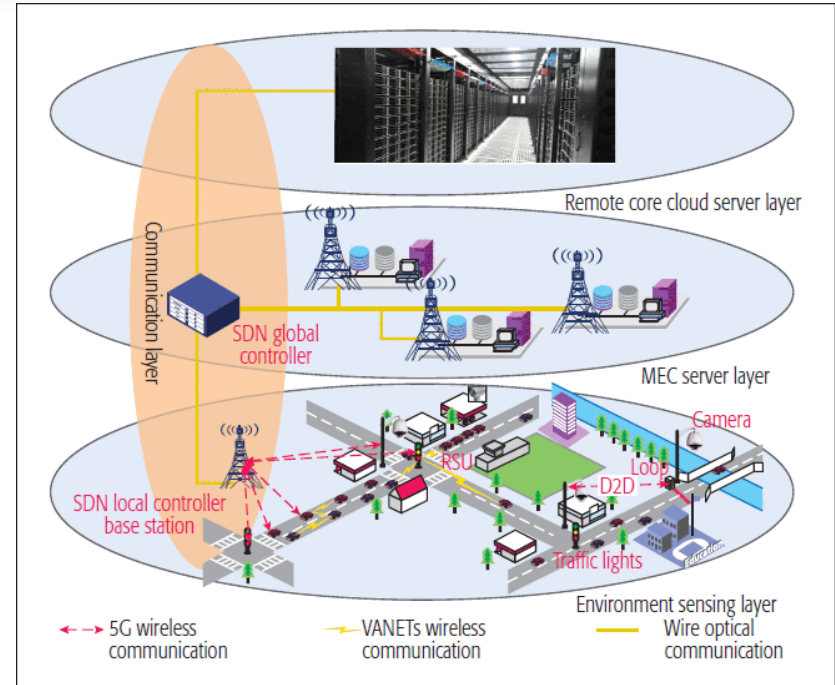

Fig. The four-tier architecture

Liu J, Wan J, Jia D, et al. High-efficiency urban traffic management in context-aware computing and 5G communication[J]. IEEE Communications Magazine, 2017, 55(1): 34-40.

3.1.1 Interaction between ITS and Information system

grassroots autonomous management

A real-time traffic management system based on crowd perception to provide a timely response for traffic management in SLOV.

The figure on the right shows a typical urban SloV system

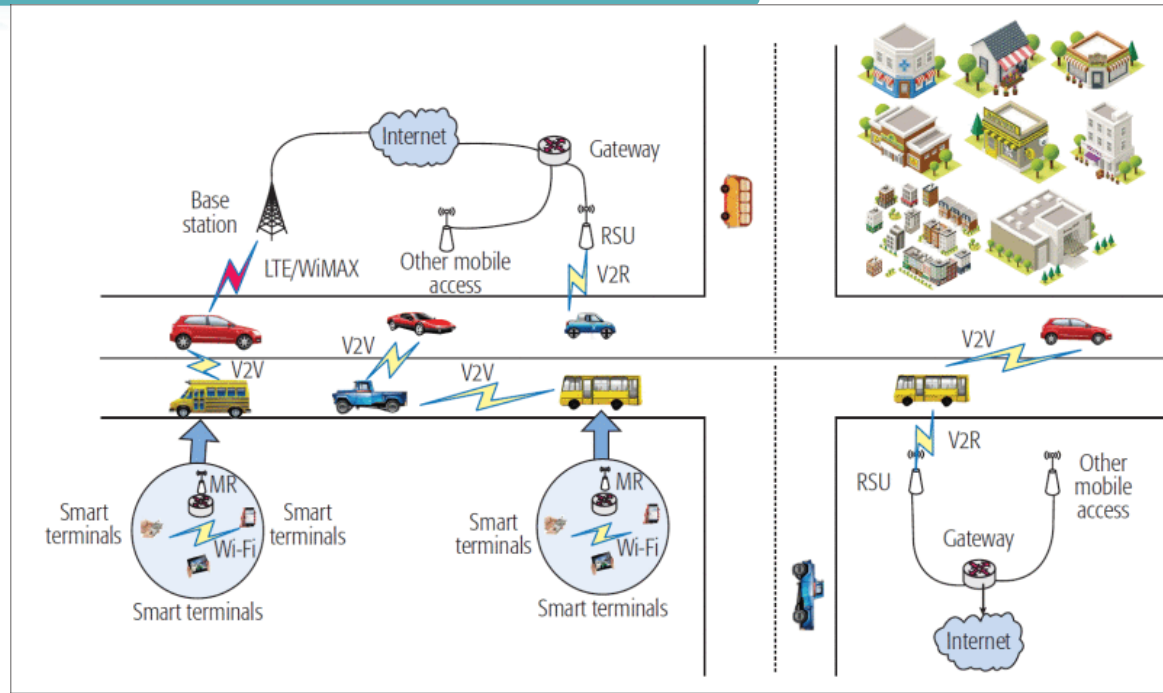

Fig. Network structures of SloV in an urban area.

Wang X, Ning Z, Hu X, et al. A city-wide real-time traffic management system: Enabling crowdsensing in social Internet of vehicles[J]. IEEE Communications Magazine, 2018, 56(9): 19-25.

3.1.1 Interaction between ITS and Information system

grassroots autonomous management

A device-to-device (D2D)-enabled real-time traffic management system by crowdsensing in SloV so that a traffic management server (TMS) can take prompt actions on timely feedback of abnormal events through vehicles on the road.

The figure on the right shows a system model of D2D-enabled SloV

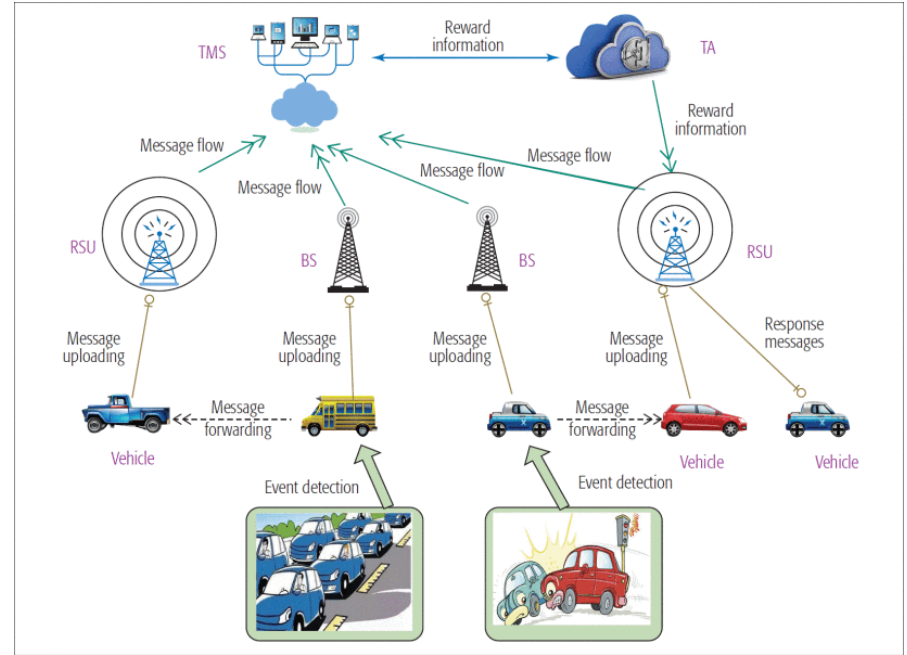

Fig. System model of D2D-enabled SloV



3.1.2 Automatic Adjustment Enabled by Closed Feedback Control Loop

The Internet has a wide range of applications in the ITS system, including the use of SLOV vehicle-borne network interaction system for traffic management and the use of Internet information to control traffic flow and vehicle distribution. These applications and concepts largely support the need for data support, feedback systems, and levels of automation.

3.1.2 Automatic Adjustment Enabled by Closed Feedback Control Loop

Traffic signal control based on reinforcement learning is a true sense of closed-loop feedback self-adaptive control and the instantaneity, accuracy, and self-learning can be guaranteed, which will be one of the future research trends.

The following figure shows the development process of the urban traffic adaptive control system predicted by Gartner et al.

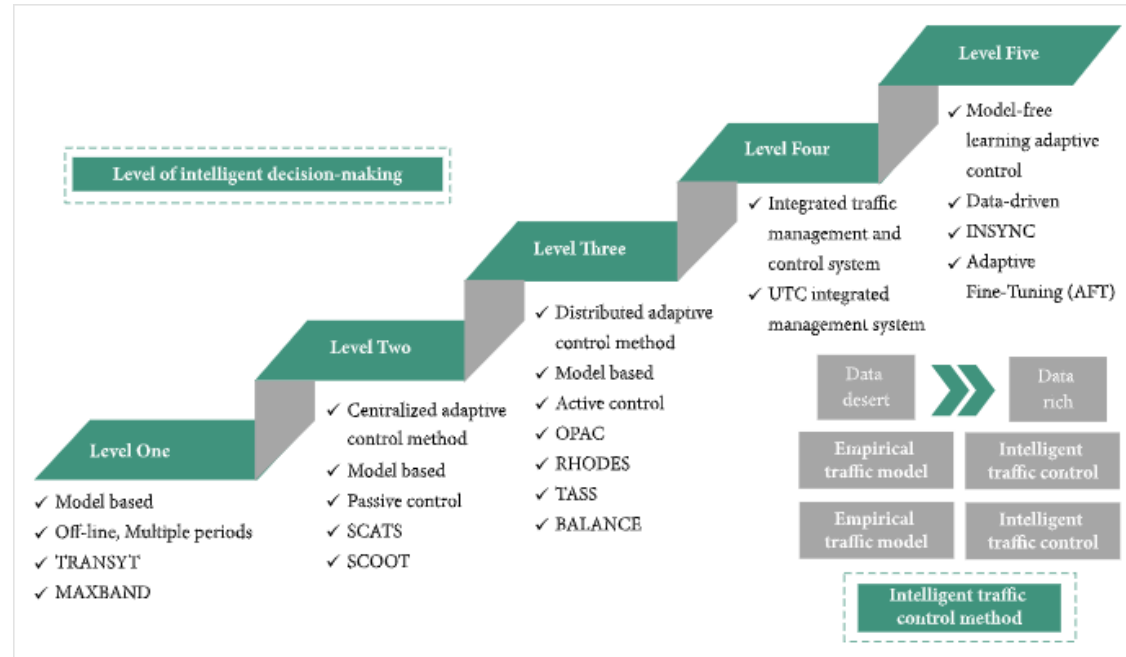

Fig. Urban traffic self-adaptive control system development process

Wang Y, Yang X, Liang H, et al. A review of the self-adaptive traffic signal control system based on future traffic environment[J]. Journal of Advanced Transportation, 2018, 2018.



3.1.3 Proactive and Human-Involved Adjustment Enabled by Information Sharing

In terms of intelligent interaction, data sharing can help individuals and groups actively adjust lifestyle and Virtual feedback loop.

At a small level, data sharing can be used to help individuals make travel choices, such as avoiding congestion based on feedback. (V2V)

At a large level, data sharing can help people raise their awareness of energy protection, develop Universal Village thinking, and choose a healthy, green and lasting lifestyle.

3.1.4 Precise Prediction and Effective Management Enabled by Data Mining

the adoption of smart card technology and automated data acquisition systems in the transportation sector has provided public transportation planners with a large and growing number of opportunities for time series data on commuter behavior and travel patterns.

The figure on the right is a case study of **Public train transport in Singapore**. the data mining technology was used to find out the different travel characteristics of **11 clusters of passengers**, which helped the government to **formulate appropriate policies**: the free travel period in the case study effectively alleviated the peak traffic pressure.

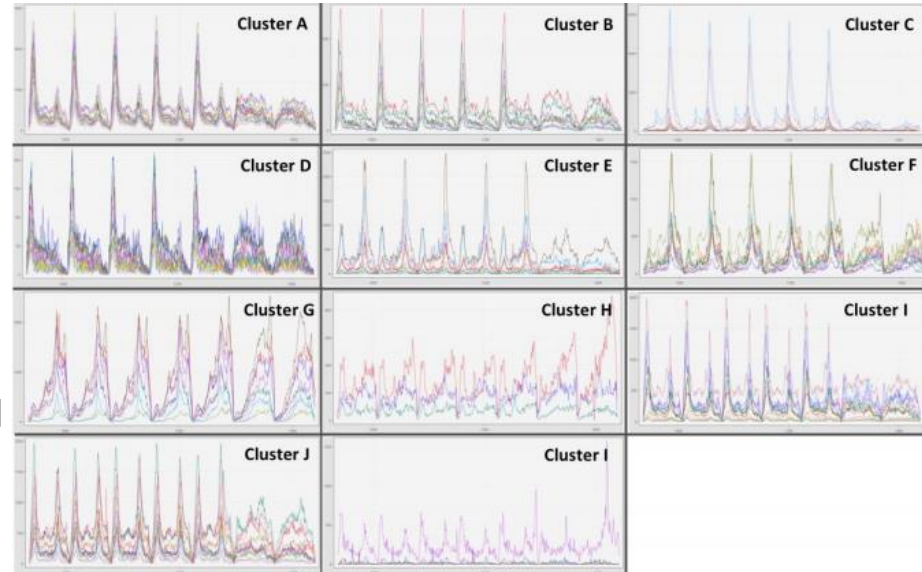

Fig. One-week time-series plot for 11 clusters



3.1.4 Precise Prediction and Effective Management Enabled by Data Mining

Innovation in technologies such as big data has revolutionized public transportation planning and other areas of transportation planning and operations.

New technologies such as big data have the following three advantages over traditional information collection methods.

1. big data sources contain updated and near or **real-time spatial** and **temporal information** that is quite impossible to collect through traditional travel survey
2. big data sources contain **a large amount** of individual level data with greater details and **higher accuracy** at **lower cost**. Some of these data can be potentially linked with supplementary data (e.g., land use, bus time tables, etc.) as well as with each other (different types of data of the same person)
3. big data sources can be used to **reconstruct large-scale trajectory data** for a larger sample size and longer observation period.



3.1.5 Open Data Policy, Data Anonymization and Encryption

Data collected can be roughly divided into two main categories: open data and classified data.

Open data is data that is or should be freely available for everyone to use and redistribute.

Classified data is information deemed by a government institution to be sensitive information that must be protected.

The decision making of 8 subsystems relies on the integrity of both open and classified data as well as the data flow among eight subsystems. Most open data resources for data flow among the UV subsystems such as maps, environment, and transport are readily available, making the UV data feedback system feasible.

3.1.6 Privacy protection

In the future traffic information system, due to the high degree of information sharing, privacy protection becomes very important

Case 1

In V2V and V2I systems, in the process of information transmission, the user's location information is transmitted in clear text, which will cause the user's privacy to be easily disclosed

Victor Sucasas et al. provides a solution, they are using encryption pseudo names to ensure users' privacy and personal data is not stolen, at the same time they have designed a kind of automatic protection certification schemes, and traffic clerk contact only once can vehicle pseudo name yourself, avoid the repeated authentication lack of hidden trouble caused by network congestion and infrastructure at the same time to ensure the accuracy and security of information.

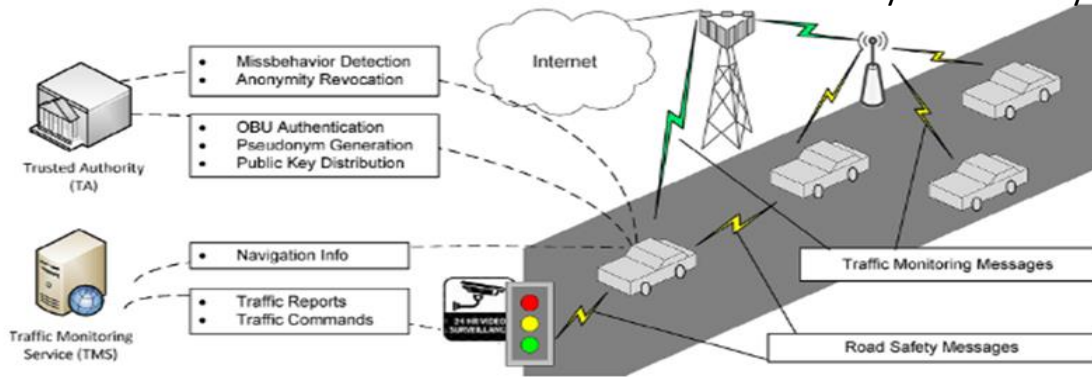

Fig. System model for traffic monitoring and road safety applications

Sucasas V, Mantas G, Saghezchi F B, et al. An autonomous privacy-preserving authentication scheme for intelligent transportation systems[J]. computers & security, 2016, 60: 193-205.

3.1.6 Privacy protection

In the future traffic information system, due to the high degree of information sharing, privacy protection becomes very important

Case 2

Crowdsourcing-based traffic monitoring plays an important role in advanced traffic management systems due to its high accuracy and low costs, but it may expose drivers real identities and sensitive locations that results in the privacy leakage of drivers.

Encrypting the driver's traffic information is a good choice for protecting the driver's privacy, but the statistical attack shown in the figure below will determine the driver's driving direction by analyzing the traffic flow.

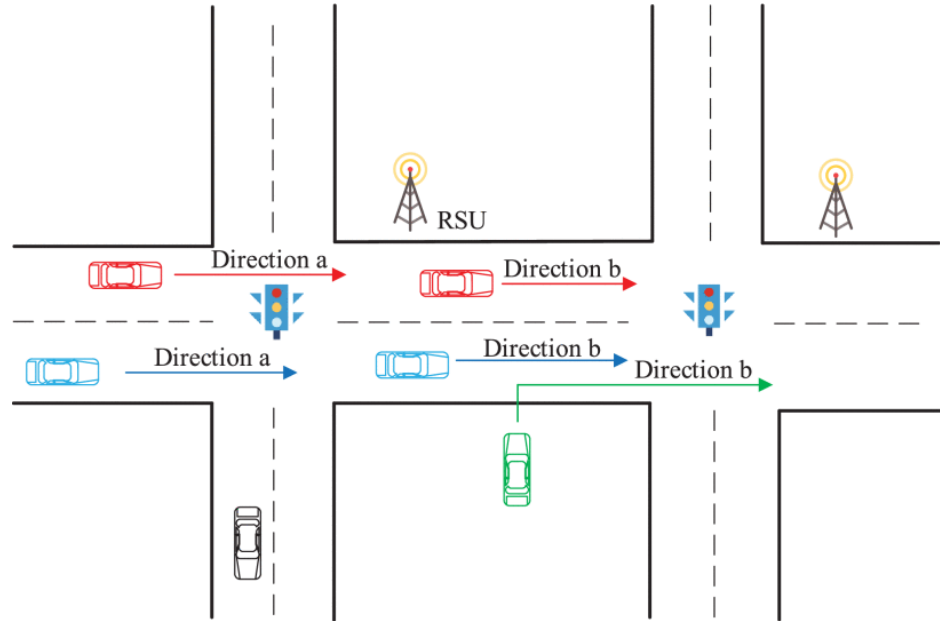

Fig. An example of statistical attack.

3.1.6 Privacy protection

In the future traffic information system, due to the high degree of information sharing, privacy protection becomes very important

Case 2

The system model of VPTS consists of the following four parties, i.e., a trusted authority (TA), a TMC, a set of RSUs, and drivers, as depicted in the right figure.

This system can enable traffic management center to obtain the decrypted traffic flow statistics without breaking the driver's privacy

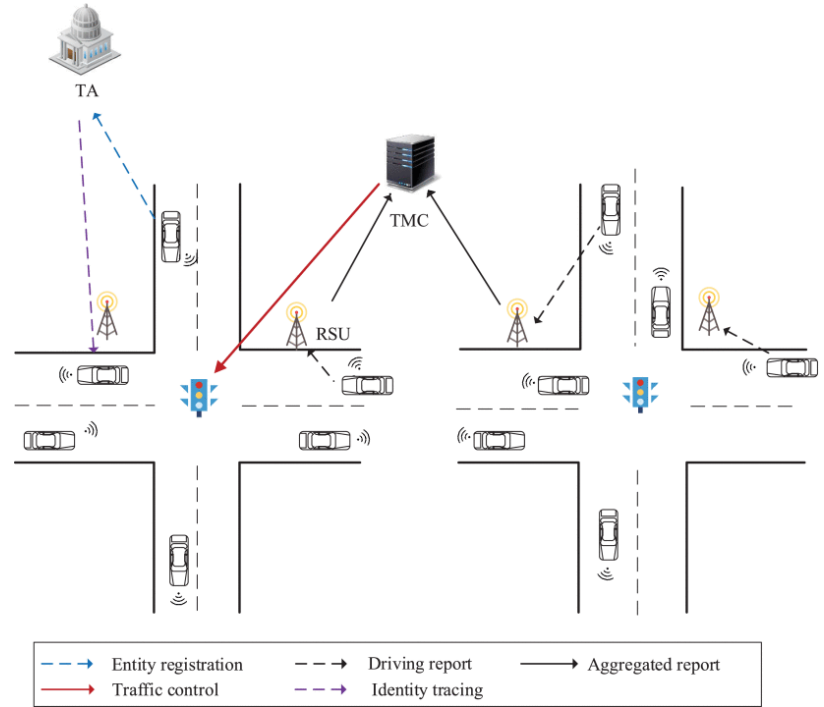

Fig. The system model of VPTS (Verifiable and Privacy-preserving Traffic Flow Statistics)

Zhang C, Zhu L, Ni J, et al. Verifiable and privacy-preserving traffic flow statistics for advanced traffic management systems[J]. IEEE Transactions on Vehicular Technology, 2020.



Summary

In this part, we focused on the information flow of ITS and studied the interaction between them. We examined two approaches: **top-down management** and **grassroots autonomous management**.

We also discussed the **Current Requirement of Information System** In ITS, as well as **privacy protection** in this part.

In the next part, we will focus on **Material Cycle**.

3.2 Material Cycle

Jiarui Zhang



3.2.1 Necessity and significance of material cycle

3.2.1.1 Interaction between ITS and material cycle

- In 2019, almost **92** million motor vehicles were produced worldwide, which will cause serious waste management and processing problem; however, if pay enough attention, these wastes can be transferred into huge profits.

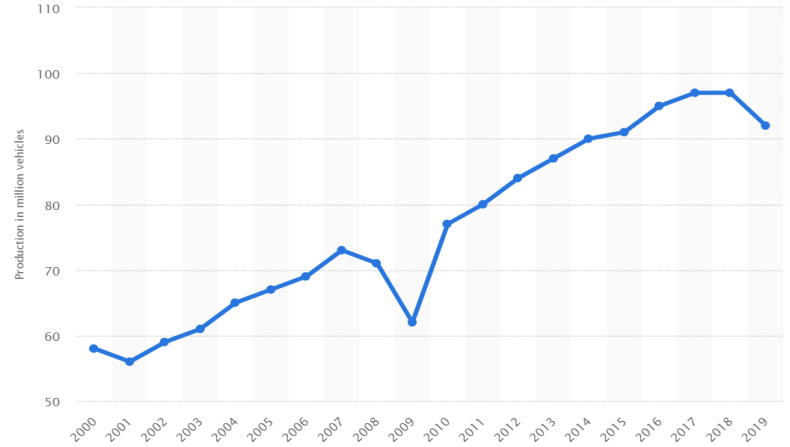

3.2.1 Necessity and significance of material cycle

3.2.1.1 Interaction between ITS and material cycle

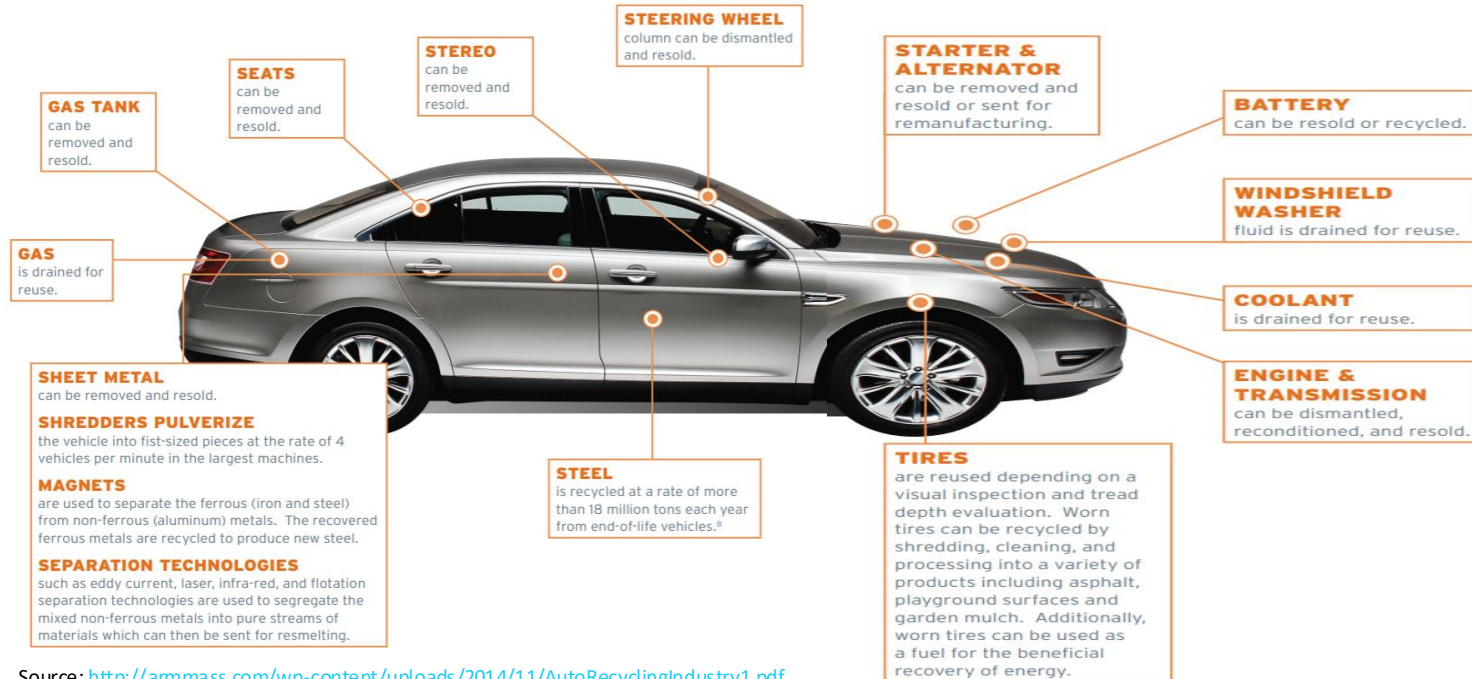

Source: <http://ammass.com/wp-content/uploads/2014/11/AutoRecyclingIndustry1.pdf>

3.2.1 Necessity and significance of material cycle

3.2.1.2. Optimize Resource Management

According to the data, every year, the automobile recycling industry in the U.S. and Canada provides **sufficient steel** to produce roughly **13 million new vehicles**.

And Every year, the North American automotive recycling industry **saves around 85 million barrels of oil**.

Furthermore, **more than 14 million tons** of recycled steel is derived from junk vehicles. On average, a car has **around 25% of its body** made from recycled steel.

Also, the automotive recycling industry supplies **around 37%** of all ferrous metal to blast furnaces and smelters across the United States. In regarding of batteries, Approximately **98% to 99%** of car batteries can be recycled

Source: <https://www.thebalancesmb.com/>

3.2.1 Necessity and significance of material cycle

3.2.1.3. Reduce Negative Environmental Impact

Batteries: Improperly disposed batteries contribute to **water and air pollution**. When depleted batteries are tossed into the trash, they end up in landfills where they decay and leak. As batteries corrode, their **chemicals soak into soil and contaminate groundwater and surface water**. So, finding methods to efficiently deal with wasted or end-of-life batteries is necessary.

Source: [https://gsiwaste.com/battery-recycling-is-important-for-environmental-health/#:~:text=1\)%20Improperly%20disposed%20batteries%20contribute%20to%20water%20and%20air%20pollution.&text=When%20depleted%20batteries%20are%20tossed,contaminate%20groundwater%20and%20](https://gsiwaste.com/battery-recycling-is-important-for-environmental-health/#:~:text=1)%20Improperly%20disposed%20batteries%20contribute%20to%20water%20and%20air%20pollution.&text=When%20depleted%20batteries%20are%20tossed,contaminate%20groundwater%20and%20)

Jambeck, Jenna R.; Geyer, Roland; Wilcox, Chris; et al. (2015). "[Plastic waste inputs from land into the ocean](#)" (PDF). *Science*. **347** (6223): 768–71. [Bibcode:2015Sci...347..768J](#). [doi:10.1126/science.1260352](#). [PMID 25678662](#). [S2CID 206562155](#). Retrieved 7 January 2019.

Plastic: Plastic pollution can afflict land, waterways, and oceans. It is estimated that **1.1 to 8.8 million tones** plastic waste enters the ocean from coastal communities each year. Living organisms, particularly **marine animals**, can be harmed either by mechanical effects, such as **entanglement** in plastic objects, problems related to **ingestion** of plastic waste, or through exposure to chemicals within plastics that interfere with their physiology. Effects on **humans** include **disruption of various hormonal mechanisms**.

3.2.1 Necessity and significance of material cycle

3.2.1.4. Provide New Opportunities for Economic Development

The car recycling industry is the **16th largest** in the United States, contributing **\$25 billion a year** to the national GDP. The U.S. automotive recycling industry employs around **100,000** people and earns around **\$25 billion a year**.



Source: <https://www.thebalancesmb.com/>

3.2.2 Current Material Cycle in ITS –Current Supporting Technologies and Platforms

3.2.2.1 New ways to recycle metals

So many products and industries require the use of precious metals. Because these minerals are so useful, they can be rather **expensive**. These materials, which include platinum, palladium, and iridium, can be used as **catalysts** in a **wide variety of industries**, including the **automotive and chemical sectors**. New methodologies like **plasma arc recycling** can help our society meet rising demands for these materials. This tech can recover a vast majority of the platinum metal found in a vehicle or other object by using a **super-hot plasma torch**. Instead of mining for new ore, we can just **reuse** these materials and give them a **second life**.

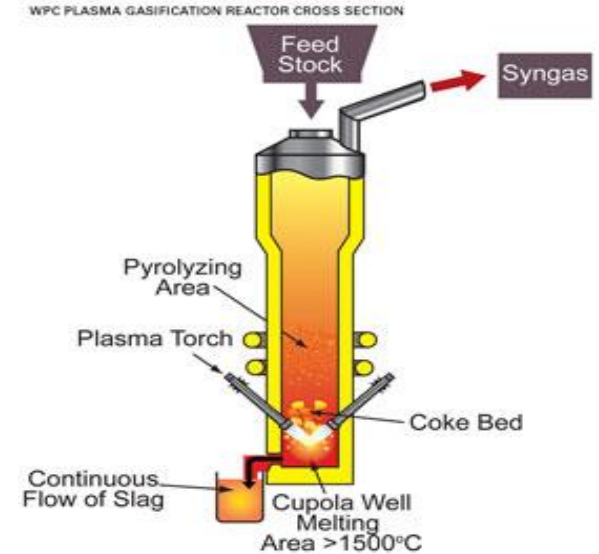



3.2.2 Current Material Cycle in ITS –Current Supporting Technologies and Platforms

3.2.2.2 Use CO₂ from car exhaust gas to separate and purify metals.

Carbon dioxide direct from a car's exhaust has been captured and used **to separate and purify metals**. The technique could offer a much-needed business incentive for capturing carbon dioxide to help **mitigate climate change** while offering a greener route for recycling economically important metals. **Carbon capture and storage** (CCS) is touted as one of the main ways to tackle global warming. But currently CCS is too **expensive** to adopt widely enough to meet climate change targets. Finding profitable ways to use captured carbon before going on to store it, however, may give CCS the boost it needs. Julien LeClair's lab at the University of Lyon, with co-workers at University of Turin, have used a dynamic combinatorial chemistry approach to show how waste carbon dioxide – even direct from a car's exhaust – can be captured by industrial amines and then used to create libraries of ligands. These ligands can then be tailored to help **separate and recover specific metals**, including lanthanum, nickel, and **cobalt** – all used in **electric vehicle batteries**.

Source: <https://www.chemistryworld.com/news/car-exhaust-fumes-could-be-used-to-clean-up-the-recovery-of-metals/4011028.article>

3.2.2 Current Material Cycle in ITS –Current Supporting Technologies and Platforms

3.2.2.2. Use CO₂ from car exhaust gas to separate and purify metals

To demonstrate the system, the team injected **diethylenetriamine (DETA)** solution – an industrial polyamine used in carbon capture – into a mixture of lanthanum chloride and nickel chloride. When exhaust fumes from a car were bubbled through this, the DETA captured carbon dioxide to produce ligands that triggered preferential binding with lanthanum. Within minutes, **lanthanum carbonate tetrahydrate crystals formed**, while **nickel bound to unreacted DETA and remained in solution**. The materials were then separated in a centrifuge at yields and **purities of 99%** for each compound.

Source: <https://www.chemistryworld.com/news/car-exhaust-fumes-could-be-used-to-clean-up-the-recovery-of-metals/4011028.article>

3.2.2 Current Material Cycle in ITS –Current Supporting Technologies and Platforms

3.2.2.2 Use CO₂ from car exhaust gas to separate and purify metals.

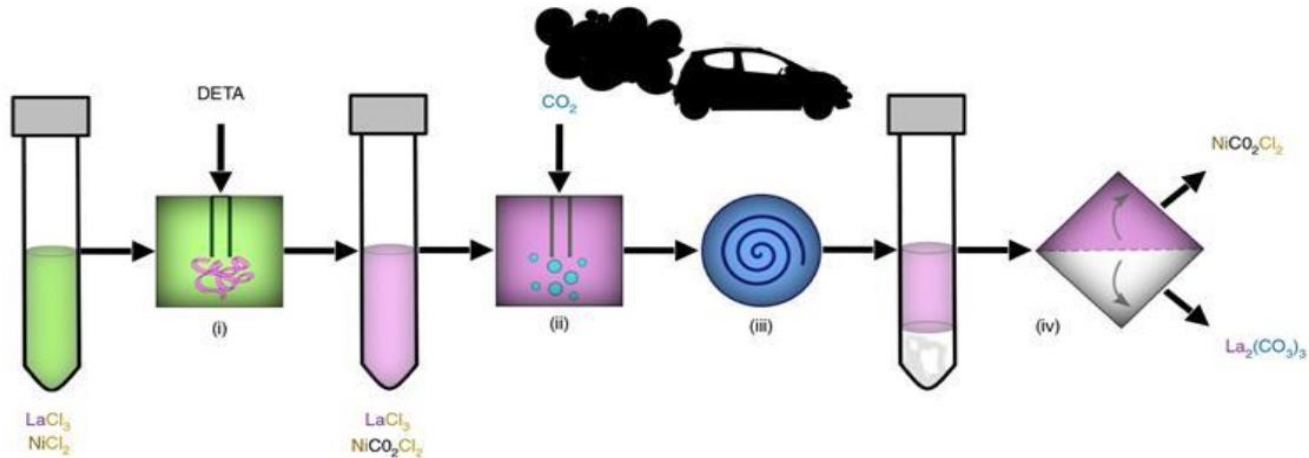

Source: <https://www.chemistryworld.com/news/car-exhaust-fumes-could-be-used-to-clean-up-the-recovery-of-metals/4011028.article>

3.2.3 UV perspective on Material Cycle in ITS - Structure of UV Material Cycle for ITS System: Closed Feedback Loop

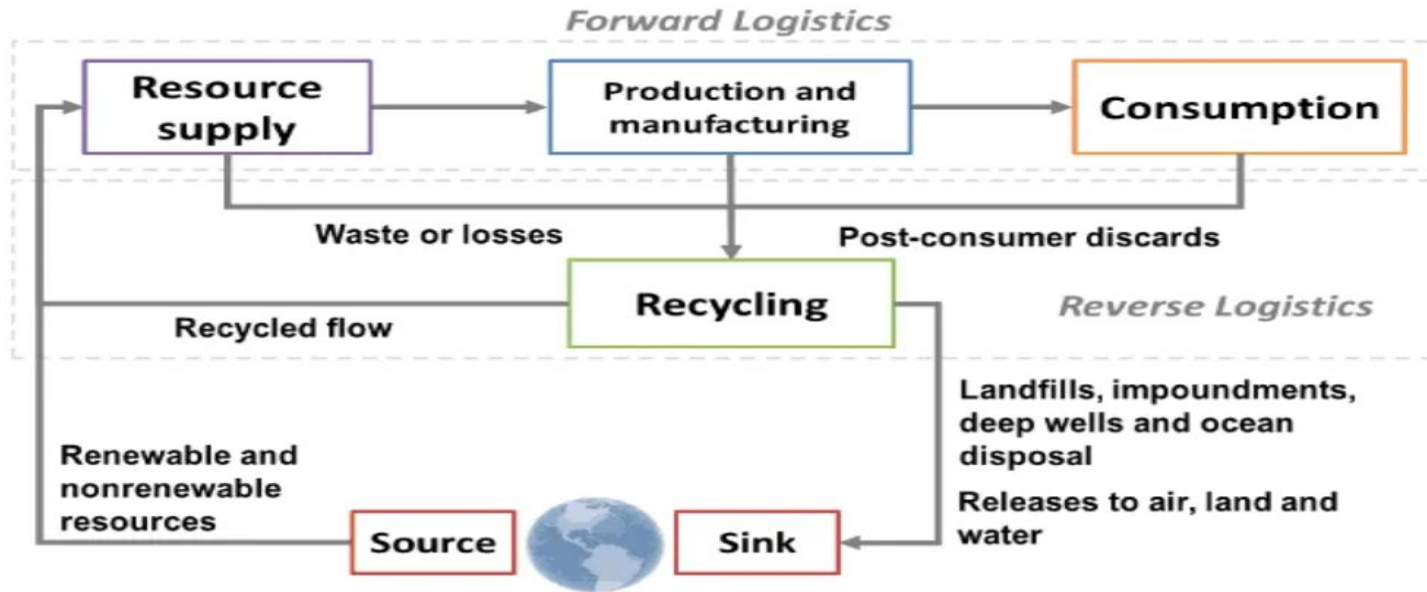

3.2.3 UV perspective on Material Cycle in ITS - Structure of UV Material Cycle for ITS System: Closed Feedback Loop

3.2.3.1 Data Acquisition- Smart waste management system

In urban environments self-compacting bins have become popular because due to a compression mechanism that can hold eight times more waste than a typical bin. However, these bins compact all the waste together **without classification**, which can lead to recyclable material becoming **contaminated**. WasteNet proposes using a deep neural network-based model to classify the waste as it is added to the bin. The following figure shows how these bins accept waste in a separate container at the top, which could easily be fitted with a **camera** to allow for images of the waste to be taken. These images would then be fed to our model, which would select the correct container for the waste to be disposed in to ensure that it would be recycled properly. These bins are also fitted with **solar panels** allowing for a **low power edge device**, such as a Nvidia Jetson Nano to run the model locally. The transparent section at the bottom of the bin shows how plastic, cardboard and paper are currently mixed and squashed together at the bottom of the bin, without waste classification



Source: WasteNet: Waste Classification at the Edge for Smart Bins

3.2.3 UV perspective on Material Cycle in ITS - Structure of UV Material Cycle for ITS System: Closed Feedback Loop

3.2.3.1 Data Acquisition- Smart waste management system

Through using convolutional neural network, Waste is classified into six categories: paper, cardboard, glass, metal, plastic and other. This model achieves a **97% prediction accuracy** on the test dataset. This level of classification accuracy will help to **alleviate some common smart bin problems**, such as **recycling contamination**, where different types of waste become mixed with recycling waste causing the bin to be contaminated. It also makes the bins more **user friendly** as citizens do not have to worry about disposing their rubbish in the correct bin as the smart bin will be able to **make the decision for them**.

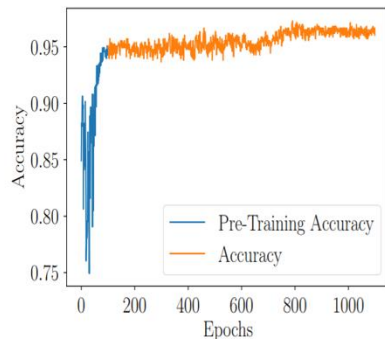
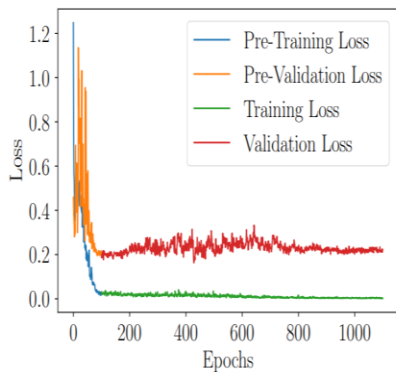

Source: WasteNet: Waste Classification at the Edge for Smart Bins

3.2.3 UV perspective on Material Cycle in ITS - Structure of UV Material Cycle for ITS System: Closed Feedback Loop

3.2.3.1 Data Acquisition- Smart waste management system

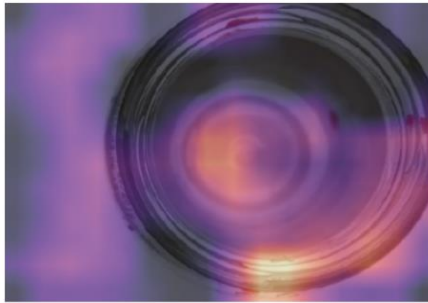

(a) Metal/Glass 9.28/0.00

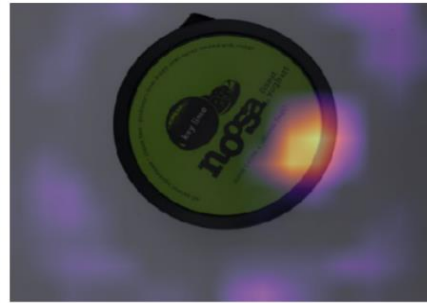

(b) Metal/Plastic 18.51/0.00



(c) Paper/Cardboard 6.16/0.00

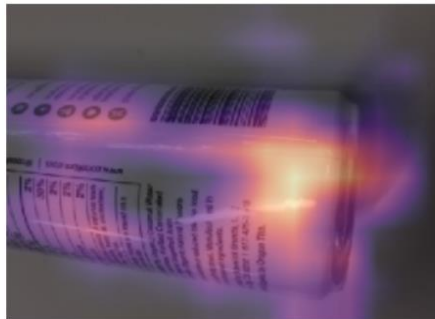

(d) Metal/Plastic 3.56/0.03

Source: WasteNet: Waste Classification at the Edge for Smart Bins

3.2.3 UV perspective on Material Cycle in ITS - Structure of UV Material Cycle for ITS System: Closed Feedback Loop

3.2.3.2. Communication

Smart waste management solutions use **sensors** placed in waste receptacles to measure fill levels and to **notify city collection services** when bins are **ready to be emptied**. Over time, historical data collected by sensors can be used to identify **fill patterns, optimize driver routes and schedules, and reduce operational costs**. The cost of these sensors is steadily decreasing, making IoT waste bins more **feasible to implement** and more **attractive to city leaders**.

Source: <https://www.iotforall.com/smart-waste-management>

3.2.3 UV perspective on Material Cycle in ITS - Structure of UV Material Cycle for ITS System: Closed Feedback Loop

3.2.3.3. Action (waste disposal)

Financing solid waste management systems is a significant **challenge**, even more so for ongoing operational costs than for capital investments, and operational costs need to be taken into account upfront. In **high-income countries**, **operating costs** for integrated waste management, including collection, transport, treatment, and disposal, generally **exceed \$100 per ton**. **Lower-income countries** spend less on waste operations in absolute terms, with costs of **about \$35 per ton** and sometimes higher, but these countries experience much more **difficulty in recovering costs**. Waste management is labor intensive and **costs of transportation** alone are in the range of **\$20–\$50 per ton**. Cost recovery for waste services differs drastically across income levels. User fees range from an average of **\$35 per year in low-income countries** to **\$170 per year in high-income countries**, with full or nearly full cost recovery being largely limited to high-income countries. User fee models may be fixed or variable based on the type of user being billed. Typically, **local governments cover about 50 percent of investment costs** for waste systems, and **the remainder comes mainly from national government subsidies and the private sector**.

Source: https://datatopics.worldbank.org/what-a-waste/trends_in_solid_waste_management.html

3.2.3 UV perspective on Material Cycle in ITS - Structure of UV Material Cycle for ITS System: Closed Feedback Loop

3.2.3.4. Interaction between Material Cycle and Subsystems

ITS material cycle and Smart Home: With better car batteries and tires recycling policies and technologies, residents can profit from their end-of-life car batteries and tires rather than just throw them away. Better still, some used car batteries can be reused as back up energy source for their homes.

ITS material cycle and Smart Energy: The used tires of vehicles can be transferred in to fuels. According to the data. Of the tires that were scrapped, 43% were burnt as tire-derived fuel, with cement manufacturing the largest user, which can relieve the current energy-shortage situation.

ITS material cycle and Smart healthcare: Novel ITS technologies can make use of the car exhaust gas which can be captured by industrial amines and then used to create libraries of ligands. These ligands can then be tailored to help separate and recover specific metals, including lanthanum, nickel, and cobalt – all used in electric vehicle batteries. This method can both reduce potential health risks caused by air pollution and gain profits.

ITS material cycle and Smart Infrastructure: Many parts of cars and bikes such as aluminum, iron, and steel can be recycled into raw material needed to build infrastructures.

3.2.3 UV perspective on Material Cycle in ITS - Structure of UV Material Cycle for ITS System: Closed Feedback Loop

3.2.3.4. Interaction between Material Cycle and Subsystems

ITS material cycle and Smart emergency: In Japan, Nissan repurposed batteries to power streetlights. Renault has batteries backing up elevators in Paris. And GM is backing up its data center in Michigan with used Chevy Volt batteries. Furthermore, old batteries can also be useful for storing solar energy and backing up traditional electrical grids, which can support country' s electric use during emergency times.

ITS material cycle and Smart Environment: With better recycling policies, batteries and plastics used in cars can be handled well, which may avoid environmental degradations caused by the leak of toxic materials from batteries and plastics.

ITS material cycle and Smart Humanity: Living in an environment with less pollution and less noise, people' s mental and physical health can be greatly improved.

Summary

In this chapter, we understand that material cycle is crucial to the development and operation of ITS. If manufacturers can disassemble their used or wasted products into reusable parts or components before products are scraped and mixed with other metals or materials at recycling centers, they can produce new component with recycled materials rather than with limited raw materials, which will greatly minimize the consumption of natural resources and increase the profits. Better still, the benefits of promoting material cycle in ITS is not limited to itself; other subsystems are also greatly benefited from it because of their mutual interactions. In the following chapter, we will discuss the interactions between subsystems in details.

PART 04

Interaction and New Perspective

Interaction between ITS and Smart Home, Smart Healthcare, Smart Energy, Smart Infrastructure, Environmental Protection, Smart Emergency, and Smart Humanity



4.1 ITS – Smart Home and Community

Yiyao Wang



4.1 Smart Home and Community

ITS, Smart home and Community are closely interrelated.

The structure and traffic condition of transportation system is influenced by residents' transport preference, travel habits and demand.

By contrast, transportation system shows impact on community livability such as noise, walking environment, land use mix, community transport, etc.





4.1 Smart Home and Community

Vehicle Choices

- 23.5 million more registered motor vehicles in U.S. from 2010 to 2018
- Alternative-fuel vehicles are more environmental and energy friendly

Solutions

- Beijing's quota system and Shanghai's auction system for car license
- Boost electric car sales by removing license plate quota
- Improve the convenience of charging infrastructure
- Design intelligent car plate for electric vehicles



4.1 Smart Home and Community

Parking in community

- Residents in Beijing's old neighborhood have to park their vehicles along roads due to inadequate parking lots in community.
- Parking lots hold an average 31% proportion of total land areas in central business streets around the world, and that in LA., Melbourne, Houston can reach 81%, 76%, and 57%, respectively.

Solutions

- London: Adjust temporary parking spaces according to local public transportation capability.
- Tokyo: People have to obtain a 'parking space certificate' before registering a car.
- Gaparking apps: Distribute the occupation of one parking spot to different vehicles with non-overlapping time.



4.1 Smart Home and Community

Avoid peak hour

Residents' overlapped commuting time slot is a huge burden for both driving and public transportation system.

Limitation of current solutions

- Crowdedness still exists with minimum bus or subway intervals.
- Potential paralyzation during emergency or festival events.
- Some companies stagger employees' commuted time, but impracticable for most industries.
- Beijing's motor plate policy limits the use of vehicles in work days force people to take crowded public transportation.

4.2 ITS – Healthcare

Jiashu Ren



4.2.1 Transportation Crowd Control

- Road rage and aggressive driving
- Situations during public transportation



4.2.2 Road Rage

- Road rage or aggressive driving are exceptionally common. NHTSA estimates over **94%** of car crashes are caused by **human error**. While anxious or angered, **50%** of the drivers tend to drive aggressively. As for the annual **30000** death in car crashes, **66%** of them are linked to an aggressive driver.
- In-car **emotion detection** can be used to sense the state of the driver via computer vision and machine learning algorithms



4.2.3 Situations during Public Transportation

- A large group of people can be seen as a **potential hazard**, let alone in a confined space like subway compartment. There should be **constant monitoring** for anything that might happen and manpower for **fast response**.
- Case: subways in China.



4.2.4 Smart Transportation in Healthcare

- Medical Delivery
- Medical Service Delivery



4.2.5 Medical Delivery

- The global medical supply delivery service market size was valued at **USD 54.8 billion** in 2019 and is expected to grow at a compound annual growth rate of **6.5%** from 2020 to 2027.
- The growing need for quick transportation and delivery of drugs and medical supplies at the time of emergencies are the key factors driving the growth of the market.
- Why people prefer medical delivery?
 - Enhanced privacy
 - Better service
 - Insurance covered
 - More convenience
 - Fast & reliable



4.2.6 Medical Service Delivery

- Medical Home
- The medical home is best described as a model or philosophy of primary care that is patient-centered, comprehensive, team-based, coordinated, accessible, and focused on quality and safety.
- Other cases such as community medical station and ambulance.



4.2.7 Smart Healthcare in Transportation

- Public transportation sterilization
- First-Aid during transportation



4.2.8 Public Transportation Sterilization

- Emergency situation: During pandemic
- Daily situation: lower chance to get ill
- Disinfecting uses chemicals to kill germs. While it doesn't necessarily clean dirty surfaces or remove germs, it kills germs and can lower the risk of spreading infection. Sanitizing is removing and lowering numbers of germs to a safe level, as judged by public health standards.



4.2.9 First-Aid During Transportation

- In buses, subway compartment and stations, etc.
- Bus: First aid kits come in handy in case of unfortunate injuries caused to the passengers inside the bus. First aid kits should be mounted in full view or labelled in an accessible place inside the driver compartment.
- Trained personnel: the bus driver or a dedicated person should be able to perform first-aid.



4.3 ITS – Smart Energy

Mo Song



4.3 ITS and Smart Energy



Source: www.sew.ai

4.3 ITS and Smart Energy

Several areas of the ITS and their relations and measures to reduce the energy consumption.

- Material Cycle
 - Urban planning issue
 - Timely maintenance of infrastructure
- Community
 - Encourage everyone to travel green, promote shared travel, shared charging, etc.

Share of total U.S. energy used for transportation, 2019

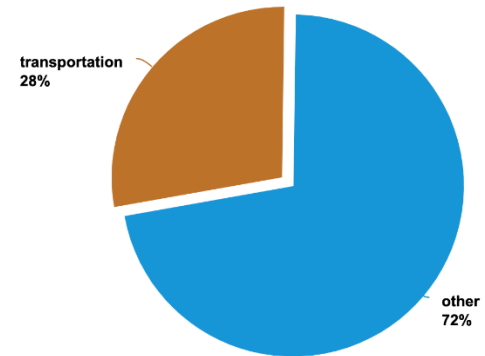

Source: U.S. Energy Information Administration, *Monthly Energy Review*, Table 2.1, May 2020, preliminary data

4.3 ITS and Smart Energy

- Lifestyle
 - Detect the condition of drivers and passengers in time
 - Prevent fatigue driving and road rage
 - Through the camera and vehicle data (driving data, driving behavior, etc.), judge the driver's driving style, give some tips and suggestions, for example, improve vehicle repair and maintenance
 - Driver scoring system, evaluation system and insurance system





4.3 ITS and Smart Energy

- Other
 - Recycling of energy
 - Timely reception and feedback of signalized intersection information
 - Avoid using the heating, cooling, lighting, audio, and fresh air in the car when it is not necessary
 - Improve forecast based on weather information

4.3 ITS and Smart Energy

- Static Information and Dynamic Information
The location of charging pile and gas station, which will affect how far the car can travel
- Safety
Risk of battery explosion

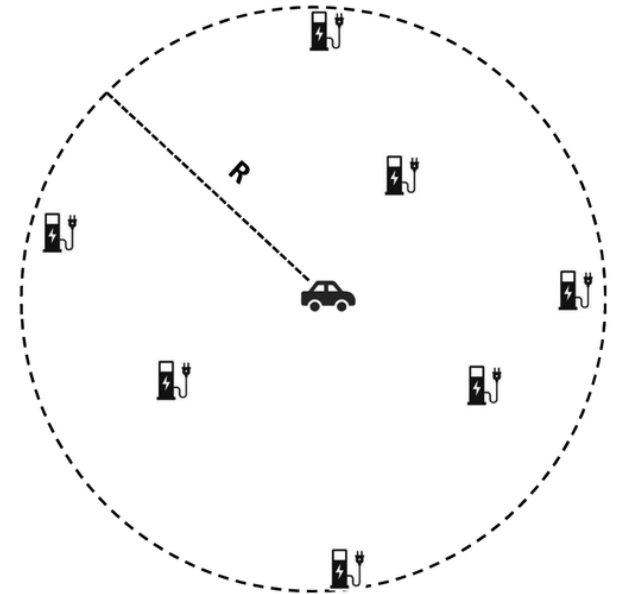

EV drivers' selection of charging stations
Source: The location optimization of electric vehicle charging stations considering charging behavior

4.4 ITS – Environmental Protection

Jiarui Zhang



4.4 Relationship between ITS and environmental protection



4.4.1 Green wave speed

The green wave speed is the speed that can ensure the **green light** when the car passes through every intersection. As the result, the more cars running at this certain speed means the **less cars crowded** at every intersection, so **the density of car exhaust will be reduced**.





4.4.2 Better routes for waste disposal

Smart waste management solutions use **sensors** placed in waste receptacles to measure fill levels and to **notify city collection services** when bins are **ready to be emptied**. Over time, historical data collected by sensors can be used to identify **fill patterns, optimize driver routes and schedules, and reduce operational costs**. The cost of these sensors is steadily decreasing, making IoT waste bins more **feasible to implement** and more **attractive to city leaders**.

Source: <https://www.iotforall.com/smart-waste-management>

4.4.3 Ideal Constant Speed

The **ideal-constant speed** traffic achieved by ITS can **improve the fuel efficiency** and **reduce the fuel consumption**

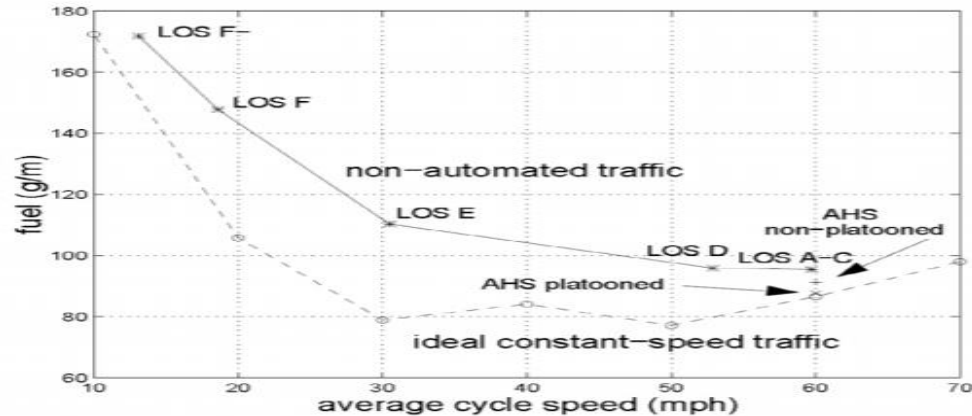

Environmentally beneficial intelligent transportation systems



4.4.4 Eco-driving

Eco-driving takes advantages of **real-time traffic sensing and telematics**, allowing for a traffic management system **to monitor traffic speed, density, and flow and then communicate advice.**



4.4.4 Eco-driving

Energy/Emissions	Non-ECO	ECO	Difference
CO₂ (g)	5439	4781	-12%
CO (g)	97.01	50.47	-48%
HC (g)	3.20	1.90	-41%
NO_x (g)	6.28	3.97	-37%
Fuel (g)	1766	1534	-13%



4.4.5 Electric Cars

1. Less pollutant emissions: With **no tailpipe**, pure electric cars produce **no carbon dioxide emissions when driving**. This **reduces air pollution considerably**. Put simply, electric cars give us **cleaner streets making our towns and cities a better place to be for pedestrians and cyclists**. Over a year, just one electric car on the roads can **save an average of 1.5 million grams of CO2** That' s the equivalent of **four return flights from London to Barcelona**.
2. Eco-friendly materials: There is also a trend towards more eco-friendly production and materials for EVs. The Ford Focus Electric is made up of recycled materials and the padding is made out of **bio based materials**. The Nissan Leaf' s interior and bodywork are partly made out of green materials such as **recycled water bottles, plastic bags, old car parts and even second hand home appliances**



Summary

Through 4.4, we understand that ITS is closely connected with environmental protection, and if people can pay enough attention to this topic, they can increase their own profits by spending less money on producing Eco-friendly cars rather than traditional cars due to the use of recyclable materials. Also, through the use of eco-friendly materials, not only can profits be enlarged, but the air quality can also be increased. In a word, generalizing the idea of the close relationship between ITS and environmental protection is beneficial for both worlds.

ITS – Infrastructure & Emergency

Yuanning Chang



4.5 ITS-Infrastructure

Smart infrastructure subsystem provides facilities for ITS





4.5.1 Information flow between infrastructure and ITS

City planning

Transportation infrastructure would influence of the transportation system

Decision making

- Smart infrastructure subsystem provides locations of gas stations, railway stations, hospitals and constructing section for ITS

Action

- Build transportation systems(railroad, bridge, tunnel, ...)
- Build new public transportation facility to avoid traffic congestion
 - Capital Bikeshare service in Washington D.C. reduces up to 4% of local traffic congestion



4.5.1 Information flow between infrastructure and ITS

Maintenance information

Decision making

- Infrastructure can provide road information for ITS in extreme weather
 - Snowy or icy roads
 - Flooded roads
 - Snow removal information
- ITS can display these information to drivers and include them to road recommendation system

Action

- When traffic accident happens, ITS can share information with Smart Infrastructure subsystem for help
- When road infrastructure is found to be damaged, it can be reported to Smart Infrastructure subsystem for maintenance



4.5.1 Information flow between infrastructure and ITS

Roadside Unit

Decision making

- Infrastructure can monitor traffic condition
 - Sensors: speed radar, weather sensor, ...
 - Traffic cameras

Action

- Electronic billboards: traffic conditions, car accidents, road maintenance information, navigation, recommend detours when congested
- Traffic light
- Lighting: provide lighting in darkness or extreme weather

4.5.1 Information flow between infrastructure and ITS

Network infrastructure

Communication

- Wireless: RFID, Bluetooth, Wi-Fi, Cellular network, ...
- Backbone network: Optical fiber, ...

Data center

Cloud computing center

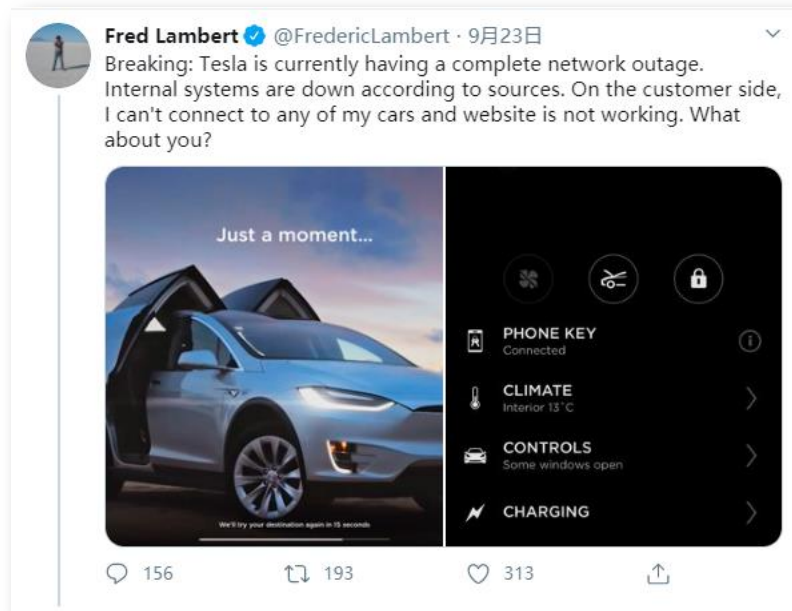

Tesla suffers a network outage in Sep. 23, 2020

Source:

<https://twitter.com/FredericLambert/status/1308785777292316672?s=20>



4.5.2 Material cycle between infrastructure and ITS

Gas station

- Provide fuel for vehicles
- Should be planned reasonably in cities to avoid congestion

Charging station for electrical vehicles

- Electric vehicles travel shorter distance and have longer recharging time
- Planning of charging stations on inter-city highways need consider the range of electric vehicles
- Add more charging pile in parking lots

Service area on highways

- Supply food and drink for drivers

4.6 Emergency Response

Smart emergency response subsystem provides works together with ITS





4.6.1 Information flow between emergency response system and ITS

Data acquisition

Emergency response system provides:

- Weather forecast and extreme weather warning
- Early warning for geological disasters(earthflow, creep, ...)
- Earthquake early warning
- Information of emergency accidents

ITS provides:

- Information of traffic accident
- Information of traffic or crowd flow
- Dangerous goods transportation vehicle monitoring



4.6.1 Information flow between emergency response system and ITS

Decision making

Decision making in ITS:

- Emergency traffic management
- Information of traffic or crowd flow
- Dangerous goods transportation route planning

Decision making in emergency response system:

- Making evacuation plan for public transportation system
- Hold evacuation drills



4.6.1 Information flow between emergency response system and ITS

Action

In ITS:

- Warn drivers and passengers of extreme weather or geological disasters
- Emergency braking when receiving an earthquake warning

In emergency response system:

- Traffic accident rescue
- Repair disaster damaged transportation infrastructure



4.6.2 Material cycle between emergency response system and ITS

Material transportation in disasters

- Medical equipment
- Food and water
- Emergency power supply equipment
- Communication equipment
- ...

4.7 ITS – Smart Humanity

Lixin Xu



4.7 ITS and Smart Humanity

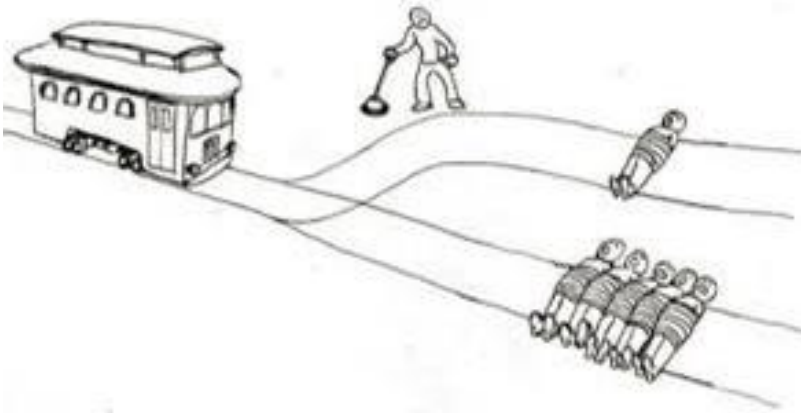

What should the self-driving car do?

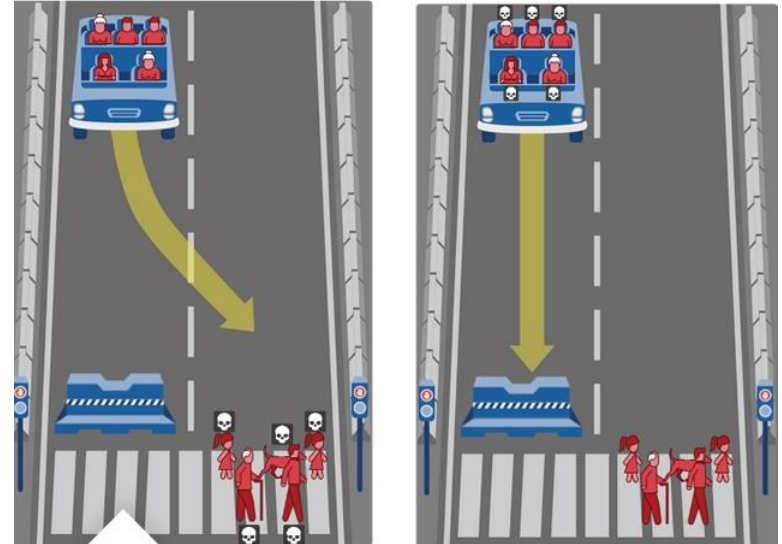

Trolley Problem and MIT's "Moral Machine"

Source: MIT Technology Review

4.7 ITS and Smart Humanity

Service and Sharing – New Construction

➤ Information infrastructure

Including 5G, IoT, industrial internet, AI, cloud computing, blockchain, data centers, and internet communication network infrastructure.

➤ Integrated infrastructure

Including inter-city high-speed rail and inner-city rail systems, charging stations for electric vehicles (EVs), and ultra-high voltage (UHV) power transmission.

➤ Innovative infrastructure

This includes R& D institutions, research infrastructure, and innovation-focused industrial parks.



Source: Xinhua net

(*) http://www.xinhuanet.com/politics/2020-04/26/c_1125908061.htm

4.7 ITS and Smart Humanity

Health – Asuke Project

- Asuke project focused on the promotion of the seniors' lives in rural areas.
- The installed sensors at their homes can measure the seniors' health conditions.
- Through automated driving technology, seniors are sent to doctors in a small-sized vehicle.
- This ensures the elderly people to be in good health conditions.



Asuke small-sized vehicle*

(*)<http://toyotamobilityfoundation.org/en/impact/asuke.html>



4.7 ITS and Smart Humanity

Happiness

Physical Happiness

- For instance, automatic anti-glare rearview mirror system [1] guarantees that the driver's eyes be protected from the glaring front light. The heating system for steering wheel [2] ensures the flexibility and convenience for using hands in cold weather.

Mental Happiness

- [3] discussed that listening to certain types of music can benefit driving performance, in which the driver reaches optimal mood-arousal level. Ambient light is another application that can attain enjoyment and prevent boredom and drowsiness during traffic congestion. With the use of driver fatigue detection technology [4], together with proper music and lighting, the driver is able to get an integrated experience that can alleviate stress, therefore promoting the overall level of happiness.

Structure of UV Subsystems

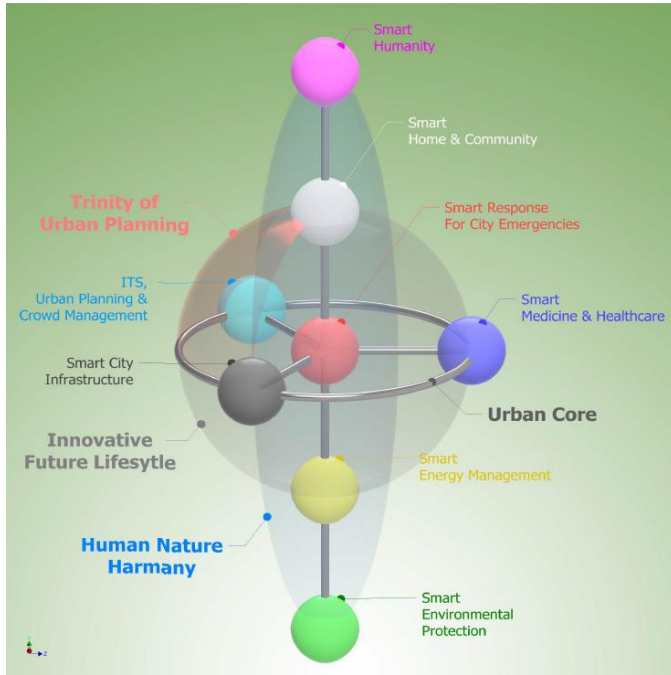

Trinity of Urban Planning

- ITS
- Smart Home
- Smart Infrastructure

Such trinity of urban planning records the daily routine activities for individual person or organization as well as usages of water, electricity, gas, networking data, etc.



Summary

In this part, we analyzed the interaction between ITS and other subsystems in UV: **Smart Home, Smart Healthcare, Smart Energy, Smart Infrastructure, Environmental Protection, Smart Emergency, and Smart Humanity**. With this kind of integration, these elements can work cooperatively and provide an integrated experience of the Smart City.

In the next part, we will focus on Part 5, **Lifestyle and Community**.

PART 05

Lifestyle and Community

How can ITS change our lifestyle and community?



5 Lifestyle and Community

Sinuo Zhao



CONTENTS

lifestyle

Choice of transportation

Fuel economy for cars

community

Community
at the national level

Focus on the elderly



5.1

Choice of transportation



Travel vehicle

energy consumption of various vehicles

Private cars



public transport

low carbon travel

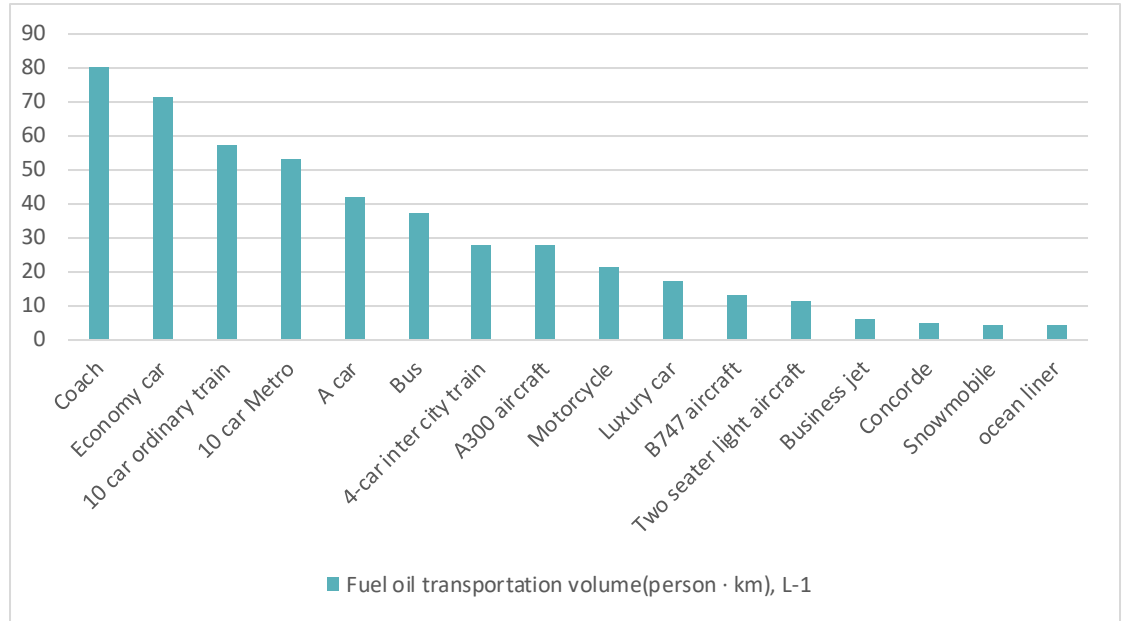

Source: Howes & Fainberg (Eds.) . The book.
American Institute of Physics

Travel vehicle

the gap
between rich
and poor.



lifestyle

Mode of transportation	Single vehicle capacity	Fuel oil transportation volume	Fuel value source	Energy consumption
	people	(person • km), L-1	MJ & LT	MJ (person • km) - 1
Coach	45	80	30.5	0.381
10 car ordinary train	800	57	30.5	0.535
4-car inter city train	200	28	30.5	1.089
A300 aircraft	267	28	29.7	1.061
B747 aircraft	360	13	29.7	2.285
Two seater light aircraft	2	11	26.2	2.400
Business jet	8	6	29.7	4.950
Concorde	110	5	29.7	5.940
ocean liner	2000	4	33.0	8.250
Source:	Howes & Fainberg (Eds.) . The book. American Institute of Physics			Energy Source-1991.

5.2

Fuel economy for cars

- ✘ Time of arrival.
The comfort level of the riding environment.
- ✔ energy consumption

idealization:

aggressively driving styles-----20%
moderate driving styles-----5~10%

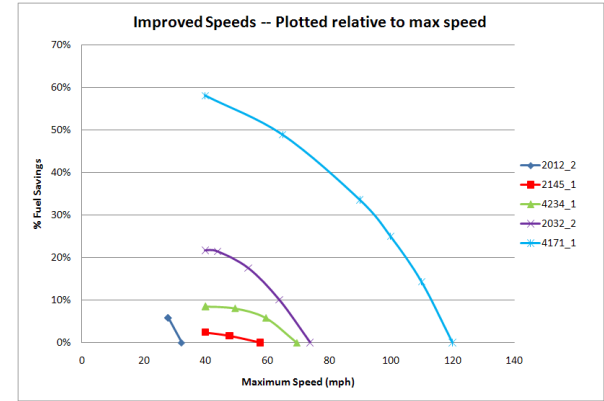
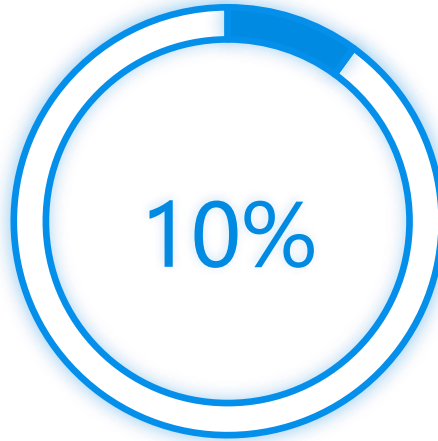
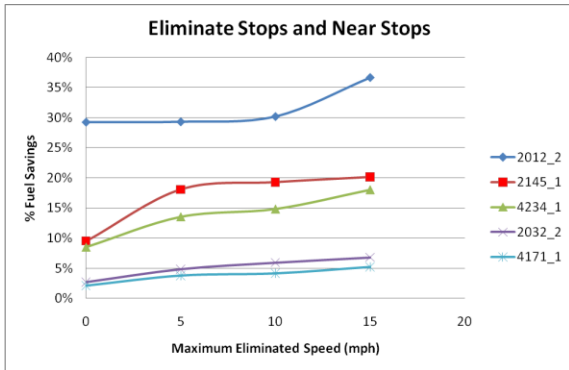

STOP habits

at least

improved speeds habit

title={Final report on the fuel saving effectiveness of various driver feedback approaches},
author={Gonder, Jeffrey and Earleywine, Matthew and Sparks, Witt},

How to achieve the energy reduction goal

change people's driving habits



give more responsibility to the vehicle

- stickers on an existing analog gauge
- app and smartphone

Intelligent driving system



New increasingly safety and convenience features such as lane assist, adaptive cruise control, and early brake application for imminent collision vehicles. The technologies to produce these features can be used to create green driving aids in which the vehicle intelligently selects optimal acceleration rates/deceleration rates and cruising. The driver's full attention then remains on the road to ensure safe operation (rather than diverting attention to a feedback device).



this automated driving process also requires energy consumption, and for those with standardized driving habits the most needed is the flight mode in the intelligent system.



ITS



lifestyle

summary



- Whether we choose **different vehicles** or have **different driving habits**, these lifestyle all constitute the **trajectory** of us in ITS system.
- The information **collection** and **processing** in ITS can make more reasonable use of resources
- but understanding the **generation** of such information (**lifestyle**) may reduce more energy consumption for ITS system form the **origin**.

5.3

Community at the national level



Proportion of RTI fatalities by road user type

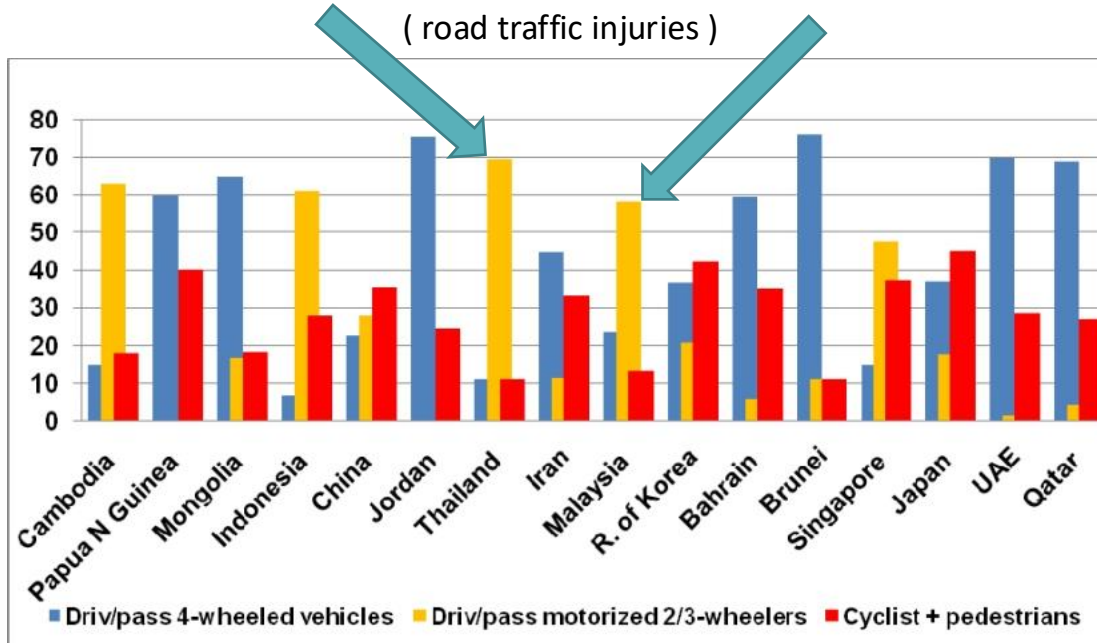

Figure 3. Proportion of RTI fatalities by road user type.

Countries are arranged in increasing per capita income from left to right
(Source: Anon 2009).



Thailand and Malaysia have a very high proportion of motorcycles compared with cars, the pedestrian fatality rate is low as pedestrians would have a lower probability of being hit by cars in this situation.

5.4

Focus on the elderly



the elderly- more likely to be injured in traffic



Considering casualties involved in Killed and Seriously Injured traffic accidents, older people have less involvement than younger groups, however, **those over 70 years, especially women**, show increasing KSI rates. Older women appear more at risk when driving in poor conditions and turning right and negotiating roundabouts, crossroads and T, Y and staggered junctions.

- Older people are more likely to be injured in traffic

the elderly-like to use private cars

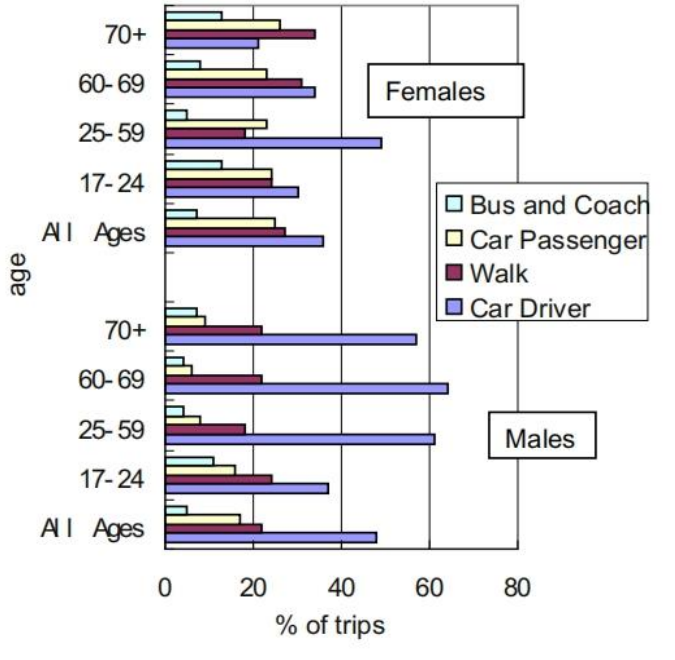

old people like to use private cars

How the trips are broken down by mode of travel is displayed in Figure. It is clear that for **males** the main mode apart at all ages from the young, is as a car driver. **Females** also drive cars but not as pronounced as males. But the data are still huge.

title={Population ageing, gender and the transportation system},
author={Li, He and Raeside, Robert and Chen, Tao and McQuaid, Ronald W},



Old people are more likely to be injured in traffic



old people like to use private cars

Add to the problem



This retention points to the need to undertake more research into **engineering solutions** to help older people whose cognitive skills are improving and this is needed especially for **women** as well as **driver training** and **cognitive improvement and development**.





ITS



community

summary



- The impact on the system is **amplified** when people with the same **lifestyle** combine into community.
- The features of **countries** and the problems of **aging populations** are just the tip of the iceberg.
- Changing their negative effects requires the use of advanced **science and technology** and **political tools**. But before we do that, we need to **find** them (The influence of the **community**)

PART 06

Modeling and Proposed Infrastructure

A high-level review of the whole work, as well as some innovative ideas

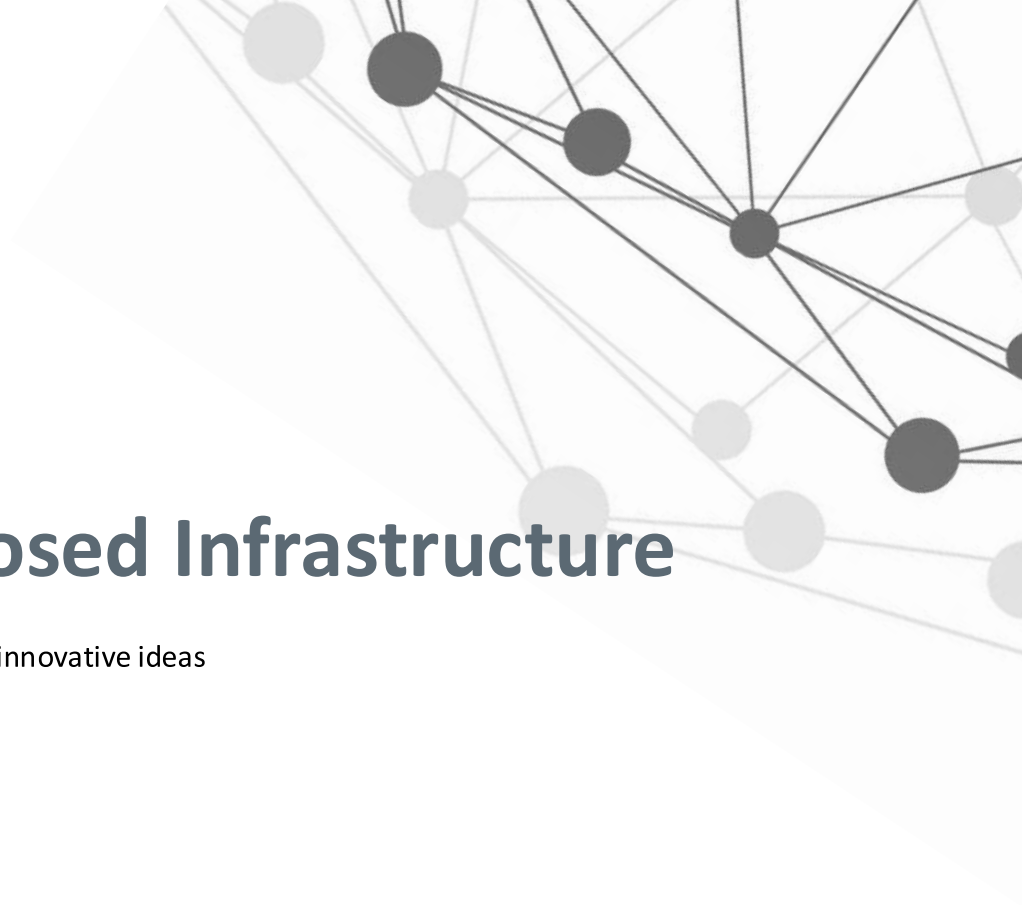



6.1 Framework

Hierarchical control variables

- Human (Pedestrian, driver, passenger, government)
- Carrier (Vehicle, vessel, airplane, train)
- Infrastructure (Parking lot, charging/gas station, road/bridge)

Performance Index

- Space
- Traffic
- Survival & Health
- Environment
- Maintenance

Control variables vs Performance index		Space	Traffic	Survival & Health	Environment
Infrastructure Design & Maintenance	Parking lot	Parking lot with special need	Multistorey car park		
	Charging/gas station	Floor area		Fire disaster	Volatility
	Road/Bridge	Width	Congestion	Deficient structures, terrorists attack	Construction material reuse
Human	Pedestrian	Pavement	Travel preference (adapt to routine)	Injuries from accidents	
	Driver			Weariness of driver, car accident, road rage	
	Passenger			Car accident	
	Government		Regulation	Insurance	Supervision
Vehicle	Design	Car size	Starting time, gradeability, braking distance, autopilot	Bad design, hazardous freights	Pollution
	Maintenance			Accident	Old part

Control variables vs Performance index		Space	Traffic	Survival & Health	Environment
From other subsystems	Home	Parking in community	Quota/auction for car plate; avoid peak hour		Domestic garbage
	Healthcare		Clearing ways for ambulance	Smart rescue system	Medical waste
	Energy		New energy vehicles		Emission
	Infrastructure	Floor area			
	Environment	Green space	New energy vehicles	PM2.5 and Respiratory diseases	Environmental protection
	Emergency	Emergency lane			
	Humanity				
Other impacting factors	Information flow	Parking availability	Congestion	Urgent care	Travel pattern
	Material cycle	Obsolete shared bicycles take up space	Recycle vehicle management		Recycling reduce environment impact
	Lifestyle		Lifestyles are shaped by environments	Health statues are deeply connected to lifestyles	Environment-friendly UV lifestyle
	Community	Crowd management	traffic congestion regulation		



6.1 System Control and Optimization

Proposed Control method in Negative Feedback Loops

	Sensing	Communication	Decision making	Action
Infrastructure	Remote sensors, weather sensors	Electronic billboards, traffic light	Traffic Management; Parking Management; Smart bus	Smart traffic light; Intersection collision avoidance, dynamic curve warning, wildlife detection
Human	Weather forecasts, traffic information	Smart phone, wearable device		Community mutual support; demand-response management
Vehicle	Sensors	ICT, 5G, V2X; electronic plate at the end of buses;	Bilateral Control	Collision avoidance, Driver monitoring, lane departure warning, automatic crash notification



6.1 Framework

Life Cycle Assessment

Infrastructure: The **construction, operation, maintenance, repair** and **demolishment** of infrastructure such as bridge or road. **Recycle** the old and recyclable materials like concrete.

Carrier / Automobile: The **manufacture, operation, maintenance, repair,** and **scrapping** of old cars.



6.2 Data acquisition

Innovative points:

- Information abundance (to ensure information accuracy)
- Static information matching & dynamic information matching (to best satisfy customers' need)



6.3 Communication

Innovative points:

Objective: Convey and communicate

➤ **Top-down management**

Transparent information and explicit purposes make it easier for traffic management.

Adjustment on the macroscopic level requires docking between information sources from other subsystems.

➤ **Grassroots autonomous management**

Grassroots autonomous management plays a huge role in terms of the V2X system of autonomous driving, platooning, and the interaction among driver, pedestrian and people with special needs (disabled, elderly, pregnancy)



6.4 Decision Making

Innovative points:

- Robustness & Self-adaptivity

- Data-Driven Predictive Models
- Multi-Criteria Decision Making
- New control variables and new causal loop
- MIMO based control strategy
- Data-driven based dynamic modeling(ITS)
- Real-time reinforcement learning model

What should we consider when we make decision about ITS?

UV ITS Framework

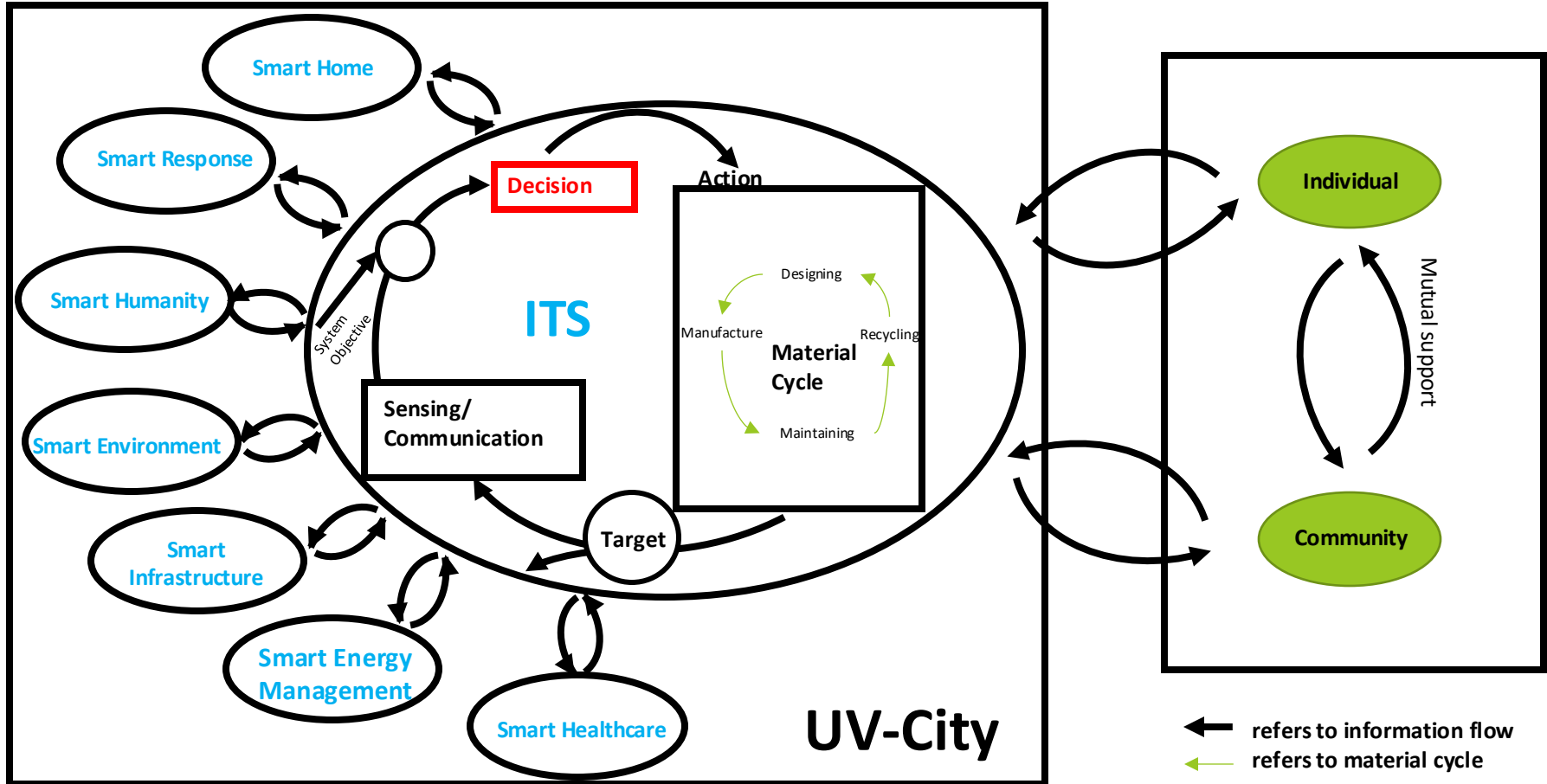

Decision Making in ITS

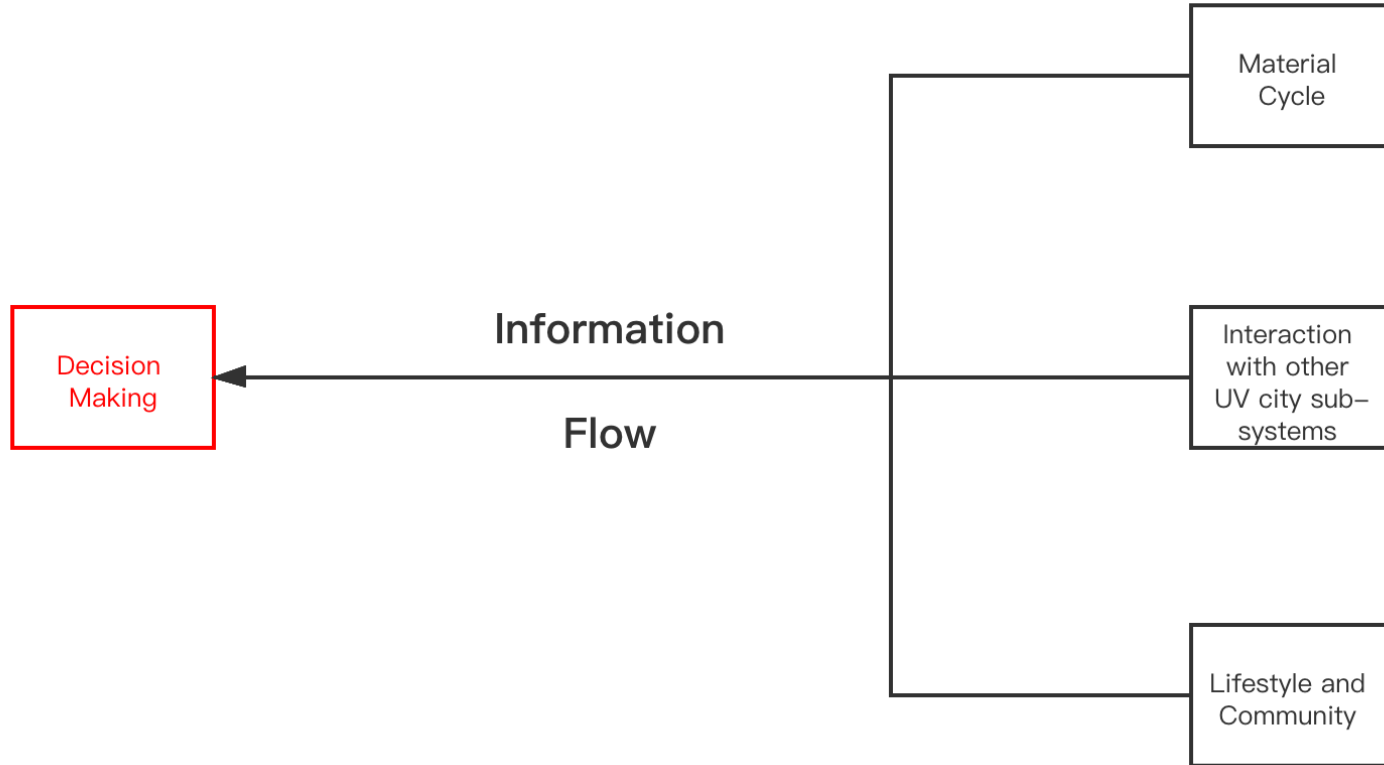

Decision Making in ITS

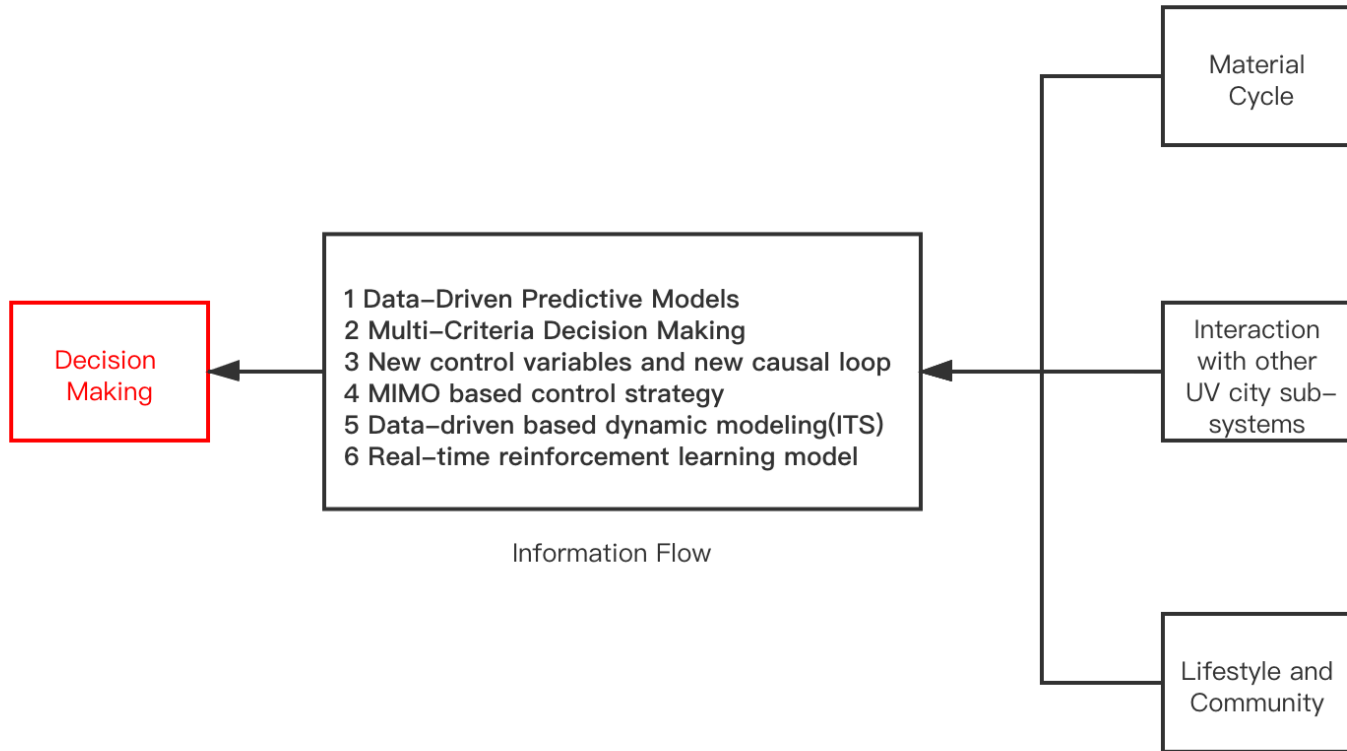

Data-Driven Predictive Models

- Typical Example: Smart Monitoring
- The shortcoming of data-driven predictive models:
 - 1 technical problems
 - 2 what if an unexpected scenario happens?

Multi-Criteria Decision Making

E.g.: Minimizing energy consumption from connected signalized intersections by reinforcement learning

- Objective: Study different Optimization Goal:

1. mini
2. mini
3. mini

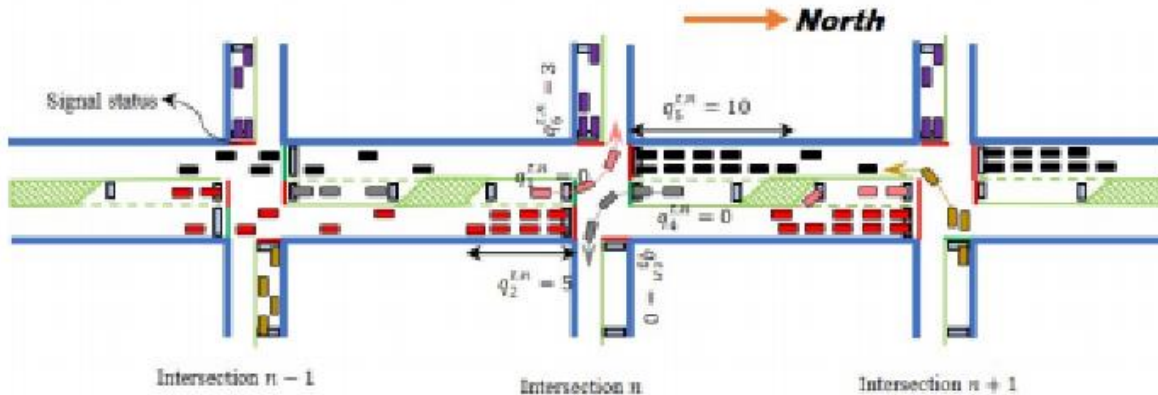

- Input: vehicle control

- Input Source: V2I, V2V, I2I communications

- Output: agent determined the number of vehicles stopped in a queue based on their speed and acceleration(out)/Signal control

This page is summarized by Jingyuan Chen.

Results from Minimizing energy consumption from connected signalized intersections by reinforcement learning

Table I System performance: Change in percentage-negative sign: Decrease, positive sign: Increase-relative to the base case

<i>Performance Metric</i>	Control Strategies		
	<i>Delay Minimize</i>	<i>Energy Minimize</i>	<i>Energy-Min with Penalty for Stops</i>
<i>Total queue time</i>	-16.8%	166.9%	50.8%
<i>Average queue time</i>	-16.7%	245.2%	51.1%
<i>System travel time</i>	-2.0%	65.6%	27%
<i>Energy consumption</i>	10.5%	-47.0%	-6.7%

New control variables and new causal loop & Data-driven based dynamic modeling(ITS)

E.g.: Vehicle to Grid (V2G)



<https://www.virta.global/vehicle-to-grid-v2g>

MIMO(Multi-input and Multi-output) based control strategy

E.g.: Prediction and Optimization Algorithms for the Energy Consumption of Electric Vehicles

De Cauwer et al. presents an energy consumption prediction method for EVs, designed for energy-efficient routing. The mean absolute error (MAE) is 12–14% of the average trip consumption.

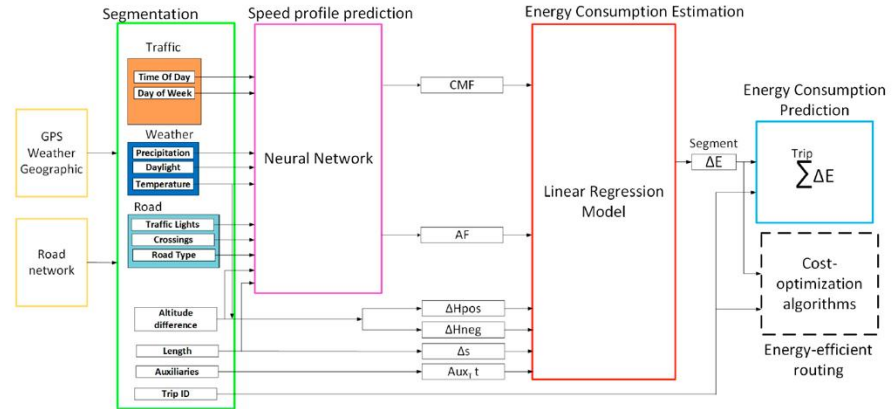
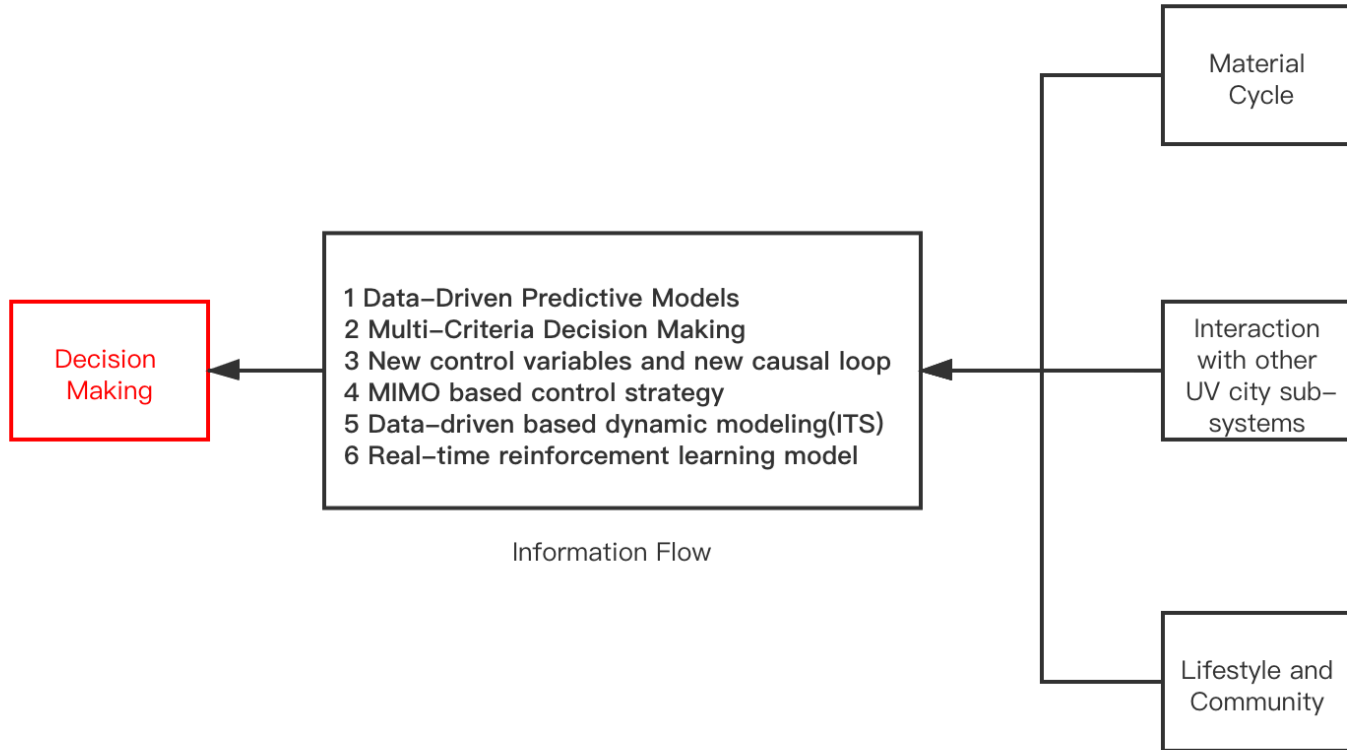

Figure 5. Detailed overview of the proposed model for energy consumption prediction. AF: aerodynamic factor; CMF: constant motion factor.

Decision Making in ITS





6.5 Action

Innovative points:

- Community support (when in emergency)
 - Demand-response management (e.g. overbook ticket /voucher or free access)
-
- Preventive Method: Maintenance & Preparation
 - Self-Treatment & Alternative Medicine
 - Coordination
 - Smart traffic management
 - Parking-lot smart management
 - Suggestion of the new lifestyle & Community-based Mutual Support
 - Post-Treatment

**THANKS FOR
WATCHING!**

